

NUMATICS®

R Series

Rack and Pinion Style Rotary Actuator Line



www.numatics.com

R Series

Features and Benefits	3
How to Order	4
Standard Specifications	5
Options	6
Cushions	6
Bumpers	6
Shock Absorbers	6
Mounting Options	7
Shaft Seal Cover and Pilot Ring	7
Shaft Options	7
Kinetic Energy Basic Formula	8
Size and Selection Example	9
Specifications	10
Port and Cushion Locations	10
Multi-Position Rotary Actuators	11-13
Switch Information	14
Sensing Part Numbers	15-17
Quick Disconnect Cables	18
R Series World Switch Hall Effect Part Numbers	18

The **R Series** is a heavy-duty rack and pinion style rotary actuator that is designed to excel in the most rigid applications. The R Series includes a high torque-to-size ratio as well as accurate positioning.

Rack and Pinion

The **rack and pinion** is made from high strength alloy steel. It is induction hardened for long life. The geometry factors of the rack and pinion have been balanced to ensure equal wear, which provides maximum gear life. The pinion shaft includes a male key as standard offering.

Ball Bearings

The **ball bearings** are sealed and pre-lubed in an effort to prevent contamination from negatively affecting the operation. They are sized to accept high loads and still retain smooth maintenance free operation.

Rack Bushing

The **rack bushing** is made from bearing bronze. The durability of the bushing enables it to support nearly the full length of the rack. Furthermore, we have included a small gap to allow grease/lubrication to be added.

Tube

The profile **tube** is hard coat anodized. The hard coating is an electro-chemical process, which produces a very dense surface of aluminum oxide. This surface has extreme hardness (60 RC.), excellent wear and corrosion resistance, and low coefficient of friction.

End Caps

The **end caps** are accurately machined from (6061-T6) solid aluminum bar stock. They are anodized for corrosion resistance. Additionally, port positioning is extremely flexible.

Piston

The solid aluminum alloy **piston** is strong and durable. A magnet groove is standard allowing for easy field conversion.

Piston Seal

The **piston seal** is a carboxylated nitrile with PTFE compound for self-lubricating. The U-cup type seal construction is proven and durable.

Wear Band

The **wear band** is a stable, lubricating strip located on the piston.

Grease Opening

A 1/4-28 tapped hole (which is plugged) is provided for future installation of an optional grease fitting. Note that the unit is pre-lubed.



Standard Specifications:

- Bore sizes from 1" through 3-1/4"
- Maximum pressure rating is 150 psi air
- Standard rotations are: 45°, 90°, 180°, 270°, and 360°
- Standard temperature -10°F to 165°F (-23°C to 74°C)
- NPTF ports
- Flexible port locating

The keyway at position 12:00, is always the mid-rotation of the actuator unless otherwise specified.

How to Order

S AR K - 180 1 C - C AA 0

Mounting

- F = Front Flange
- R = Rear Flange
- P = Pilot Ring
- B = Bottom Flange
- S = Standard Mount

Type

- AR = Single Rack
- BR = Double Rack
- CR = 3 Position Single Rack
- DR* = 4 Position Single Rack
- ER** = 5 Position Single Rack

* Must specify X dimension.
** Must specify X and Y dimensions.

Size

- E = 1" Bore
- K = 1-1/2" Bore
- L = 2" Bore
- M = 2-1/2" Bore
- P = 3-1/4" Bore

Degrees Rotation

- 045 = 45°
- 090 = 90°
- 180 = 180°
- 270 = 270°
- 360 = 360°

Any degree of rotation can be specified.

Consult factory for rotations of or greater than 1000°

Rod End Code

- 1 = Single Male Keyed (Std)
- 2 = Single Female Keyed
- 3 = Double Male Keyed
- 4 = Preloaded Keyway

Magnetic Piston

- 0 = No Magnet
- 2 = Magnet

Options

- AA = No Options
 - BA = Bumpers Both Directions
 - BC = Bumpers Counterclockwise
 - BH = Bumpers Clockwise
 - KA* = Angle Adjustment Both Directions
 - KC* = Angle Adjustment Counterclockwise
 - KH = Angle Adjustment Clockwise
 - PP = Polypak Piston Seals
 - SA = Shock Absorbers Both Directions
 - SC = Shock Absorbers Counterclockwise
 - SH = Shock Absorbers Clockwise
 - SS = Shaft Seal Covers
 - VA = FKM Seals
- *N/A with the SA, SC, and SH options

Cushions

Position	Standard			
No Cushion	A	A	A	A
CW and CCW	B	C	D	E
CW	F	G	H	J
CCW	K	L	M	N

CW = Clockwise
CCW = Counter-clockwise

Ports

Position	Size Code			
	1/8	1/4	3/8	1/2
1	B	C	D	E
2	H	I	J	K
3	N	O	P	Q
4	T	U	V	W

Cushion and Port Positions

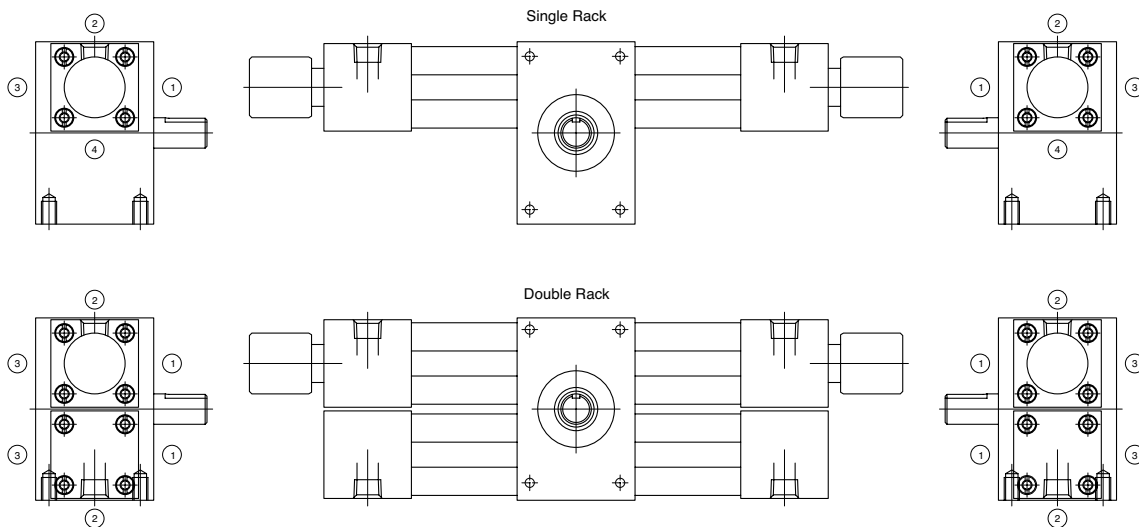

PORTS SHOWN IN POSITION 2. S = STANDARD, A = AVAILABLE

NOTE: Consult factory for repair kit information.

Standard Specifications

Maximum operating pressure: 150 psi pneumatic
 Standard rotations: 45°, 90°, 180°, 270°, 360° and other rotations optional
 Operating temperature: 0° F to 180° F (standard seals)
 0° F to 400° F (FKM seals)

Bore	Number of Racks	Model	Theoretical Torque Output (in-lbs)			Displacement Cu. In./Deg. of Rotation	"Max. Angular Backlash, Minutes"	Max. Rotational Total (Degrees)
			50 psi	100 psi	150 psi			
1"	1	SARE	19	39	59	0.007	50	10
1"	2	SBRE	39	79	118	0.014	50	10
1 1/2"	1	SARK	59	118	177	0.021	40	8
1 1/2"	2	SBRK	118	236	353	0.042	40	8
2"	1	SARL	141	282	424	0.049	30	6
2"	2	SBRL	282	565	848	0.099	30	6
2 1/2"	1	SARM	276	552	828	0.096	30	6
2 1/2"	2	SBRM	552	1104	1656	0.193	30	6
3 1/4"	1	SARP	570	1141	1711	0.199	15	4
3 1/4"	2	SBRP	1141	2281	3422	0.398	15	4

Dimensions: Inches

Standard Mount

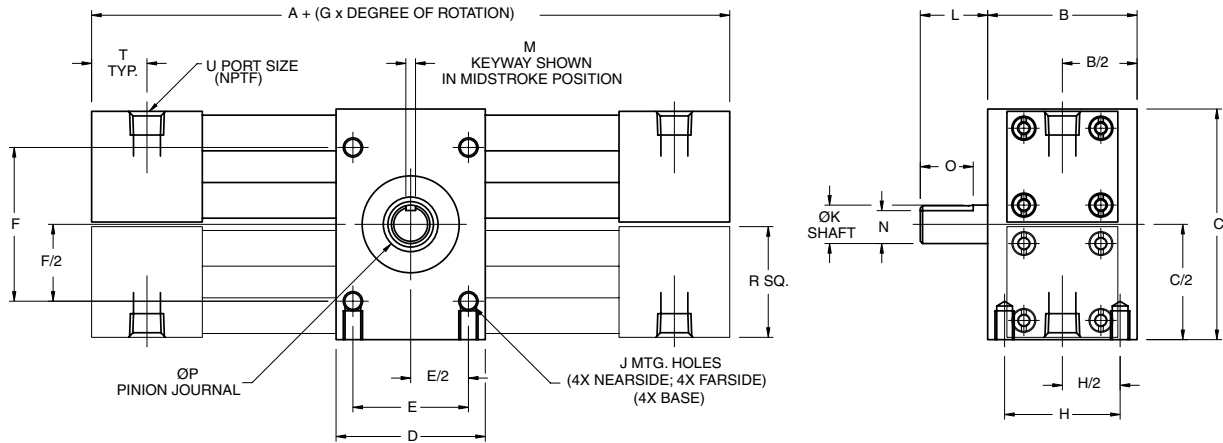

Bore	A	B	C	D	E	F	G	H	J	K	L	M	N	O	P	R	T	U	V
1"	7.50	2.00	3.00	2.00	1.50	2.00	0.01746	1.50	1/4-20 X 3/8 DEEP	.500/.499	0.88	.125/.127	.430/.425	.625	0.59	1.44	0.75	1/8	0.75
1 1/2"	8.50	3.00	4.25	3.00	2.00	3.00	0.02328	2.00	5/16-18 X 1/2 DEEP	.875/.874	1.88	.188/.190	.771/.761	1.50	0.98	2.00	0.75	1/4	1.13
2"	9.50	3.00	5.00	4.00	2.50	3.50	0.03124	2.00	3/8-16 X 1/2 DEEP	1.125/1.124	1.88	.250/.252	.986/.976	1.50	1.18	2.44	0.75	1/4	1.25
2 1/2"	9.75	3.50	6.00	4.00	2.50	4.50	0.03926	2.00	1/2-13 X 3/4 DEEP	1.375/1.374	2.25	.313/.315	1.201/1.191	1.75	1.57	2.94	0.75	1/4	1.50
3"-1/4"	11.25	5.00	8.00	5.00	3.00	5.00	0.04800	2.50	3/4-10 X 1 DEEP	1.750/1.749	3.50	.375/.377	1.542/1.532	3.00	1.77	3.75	0.88	3/8	1.94

Options

Rotation Adjust

Rotation adjusting knobs can be added to control rotation more precisely. They can be used on both ends or on either end individually. Rotation adjusters can be used in conjunction with cushions. Their "high tech" style makes rotation adjustment easy to do without tools. The metric set screw in the side of the knob securely locks the rotation setting. Thus, the rotation is very easy to adjust, but cannot be changed without a metric Allen wrench. When used with cushions, maximum rotation adjustment will still allow at least 20° of rotation to be in cushion.

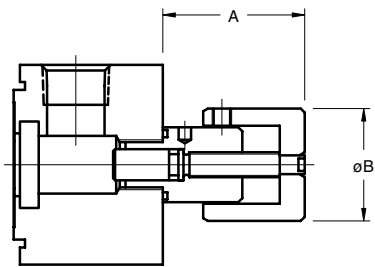

Bore	A	B	Degree of Rotation Per End
1"	1.43	1.13	43
1 1/2"	1.43	1.13	32
2"	2.22	1.75	40
2 1/2"	2.22	1.75	32
3 1/4"	2.67	2.35	32

Cushions

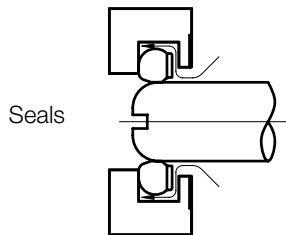

Our cushion seal has a built-in function. It seals in one direction and permits full flow in the opposite direction.

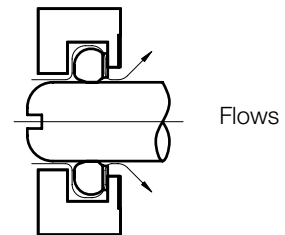

Cushions can be added to meter deceleration. Cushion adjustment needles can be put in any quadrant. Normally, cushions will be added to only one half of the double rack unit. The cushion and its operation are very similar to our current A series design. Rotation adjust can be used in conjunction with cushions. Cushions and shock absorbers together are not available.

Bumpers

Bumper seals can be added to reduce impact. The bumper and seal are one piece. Bumpers can be used in conjunction with cushions if necessary.

NOTE: Cannot be used with rotation adjustment.

NOTE: Silencer Bumper does not add length to the cylinder, but a minimum force of 100PSI must be applied to collapse the seals to reach the full extend and retract positions.

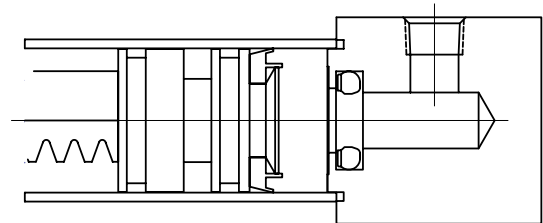

Shock Absorbers

Hydraulic shock absorbers can be added to reduce noise and large impacts. Shocks are fixed orifice self-compensating type. The 3 1/4" bore rotary actuator will not have this option. Cushions and shock absorbers together are not available.

NOTE: Shock cannot be adjusted.

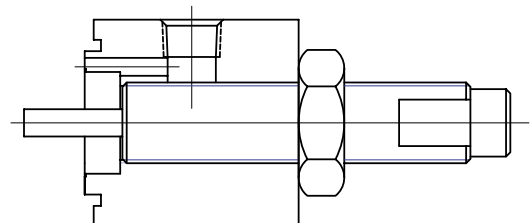

Mounting Options

Flanges

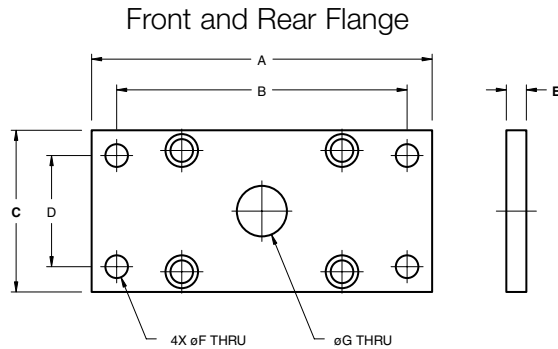

Bore	A	B	C	D	E	F	G
1"	4.25	3.63	2	1.38	0.25	9/32	5/8
1 1/2"	5.75	5.13	3	2.13	2.13	13/32	1
2"	6.50	5.88	4	3.38	3.38	13/32	1 1/4
2 1/2"	8.25	7.25	4	3.00	3.00	17/32	1 5/8
3 1/4"	12.00	10.00	5	3.00	3.00	25/32	2

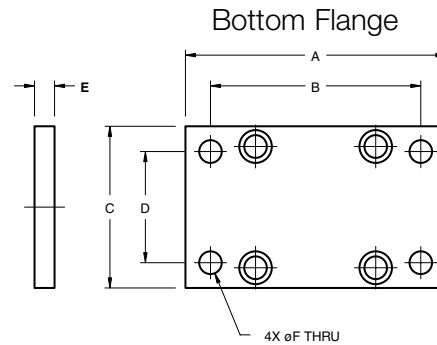

Bore	A	B	C	D	E	F
1"	3.25	2.63	2	1.38	0.25	9/32
1 1/2"	4.50	3.88	3	2.13	0.44	13/32
2"	4.50	3.88	4	3.38	0.44	13/32
2 1/2"	5.50	4.50	4	3.00	0.44	17/32
3 1/4"	8.00	6.50	5	3.50	0.75	25/32

Shaft Seal Cover and Pilot Ring

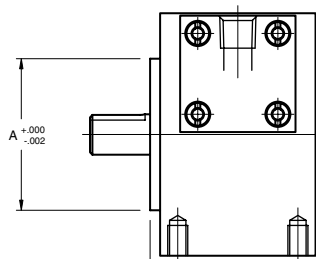

Bore	A	B
1"	1.875	0.125
1 1/2"	3.000	0.250
2"	3.250	0.250
2 1/2"	3.625	0.250
3 1/4"	4.480	0.250

The pilot ring and the shaft seal cover are dimensionally the same. Pilot rings are used to help center the shaft to the work piece. Shaft seal covers are used to prevent contamination to the ball bearings. They can only be used on single and double male shafts.

Shaft Options

Double Male Keyed

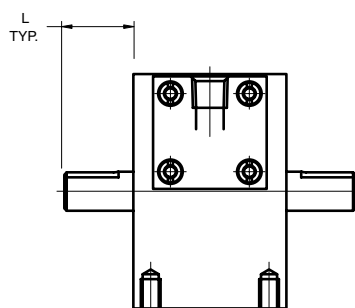

Bore	L
1"	0.875
1 1/2"	1.875
2"	1.875
2 1/2"	2.250
3 1/4"	3.500

Bore	A	B	C	D	E
1"	1.81	0.59	0.250	N/A	N/A
1 1/2"	2.69	0.98	0.500	0.125	0.560
2"	2.72	1.18	0.688	0.187	0.780
2 1/2"	3.13	1.57	0.813	0.250	0.901
3 1/4"	4.56	1.77	1.125	0.187	1.247

Single Female Keyed

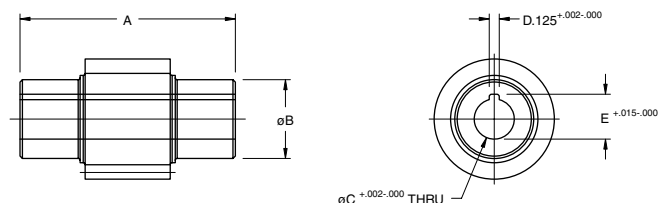

Kinetic Energy Basic Formula

$$KE = 1/2 J\omega^2$$

$$\omega = 0.035 \times \frac{\text{Angle traveled (degrees)}}{\text{Rotation time (seconds)}}$$

Where:

- KE = Kinetic Energy (in-lb)
- J = Rotational mass moment of inertia (in-lb-sec²)
(Dependent on physical size of object and weight)
- ω = Peak Velocity (rad/sec)
(Assuming twice average velocity)
- W = Weight of load (lb)
- g = Gravitational constant = 386.4 in/sec²
- r = Radius of gyration (in)

Moments of Inertia

Maximum Kinetic Energy Rating for Models Based on Configuration (in-lb)

Bore	Standard	Rotation Adjusters	Cushions	Shock Absorbers (Per Cycle/Per Hour)
1"	0.50	0.50	5	150/300,000
1 1/2"	2.00	2.00	20	225/400,000
2"	4.00	4.00	40	600/600,000
2 1/2"	7.00	7.00	70	600/600,000
3 1/4"	15.00	15.00	150	N/A

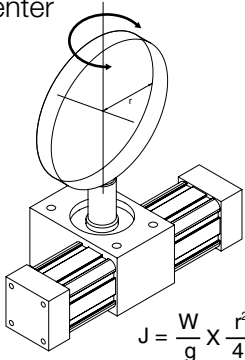
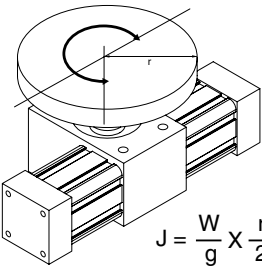
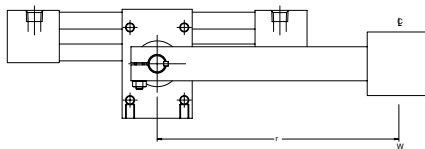
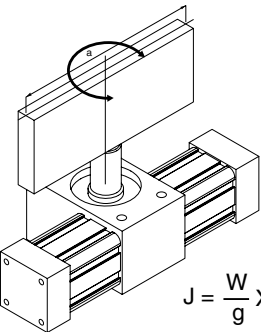
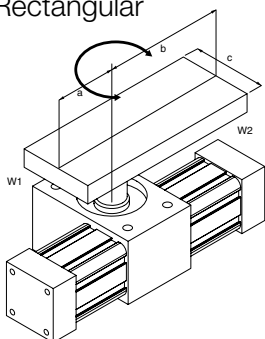
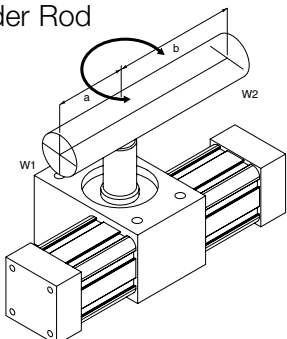
<p>Thin Disk-End mounted on center</p>  $J = \frac{W}{g} \times \frac{r^2}{4}$	<p>Thin Disk-Mounted on center</p>  $J = \frac{W}{g} \times \frac{r^2}{2}$	<p>Point Load</p>  $J = \frac{W}{g} \times r^2$
<p>Thin Rectangular Plate-Mounted on center</p>  $J = \frac{W}{g} \times \frac{a^2}{12}$	<p>Thin Rectangular Plate</p>  $J = \frac{W1}{g} \times \frac{4a^2 + c^2}{12} + \frac{W2}{g} \times \frac{4b^2 + c^2}{12}$	<p>Slender Rod</p>  $J = \frac{W1}{g} \times \frac{a^2}{3} + \frac{W2}{g} \times \frac{b^2}{3}$

Size and Selection Example

Point load application

W=5 lb. load

r=12 inch arm length

Want to use 1 1/2 bore rotary actuator

Need to rotate 180 degrees in 2 seconds

Should I use bumpers, cushions, shocks, or none of these?

From Catalog:

$$\omega = 0.035 \times \frac{\text{Angle traveled (DEG)}}{\text{Rotation time (SEC)}}$$

$$\omega = 0.035 \times \frac{180 \text{ DEG}}{2 \text{ SEC}}$$

$$\omega = \frac{3.15}{\text{SEC}}$$

$$J = \frac{W}{g} \times r^2$$

$$J = 5 \text{ LB} \times \frac{\text{SEC}^2}{386.4 \text{ IN}} \times \text{IN}^2$$

$$J = 1.86 \text{ IN-LB-SEC}^2$$

$$KE = 1/2 J\omega^2$$

$$KE = \frac{1}{2} \times 1.86 \text{ IN-LB-SEC}^2 \times \left(\frac{3.15}{\text{SEC}}\right)^2$$

$$KE = 9.23 \text{ IN-LB}$$

Looking at Kinetic Energy Rating Chart:

Maximum KE=20 IN-LBS for a 1 1/2" bore rotary with cushions

Therefore, application requires cushions.

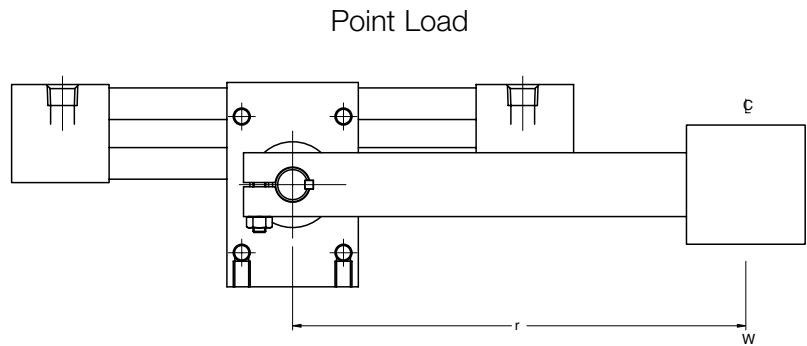

$$J = \frac{W}{g} \times r^2$$

Maximum Kinetic Energy Rating for Models Based on Configuration (in-lb)

Bore	Standard	Stroke Adjusters	Cushions	Shock Absorbers (Per Cycle/Per Hour)
1"	0.50	0.50	5	150/300,000
1 1/2"	2.00	2.00	20	225/400,000
2"	4.00	4.00	40	600/600,000
2 1/2"	7.00	7.00	70	600/600,000
3 1/4"	15.00	15.00	150	N/A

Specifications

Unit Weights (lbs)

Model	Rotation (Degrees)			
	90	180	270	360
SARE	3	3	3	3
SBRE	4	4	4	5
SARK	9	9	10	10
SBRK	12	13	14	15
SARL	14	15	16	17
SBRL	20	22	24	27
SARM	22	23	25	27
SBRM	31	34	38	41
SARP	45	47	49	52
SBRP	62	67	72	77

Bearing Load Capacities

Bore	Radial Load (lb)	Thrust Load (lb)	Distance Between Bearings (in)
1"	100	75	1.40
1 1/2"	300	200	2.15
2"	500	350	2.15
2 1/2"	900	600	2.50
3 1/4"	1300	900	3.75

Port and Cushion Locations

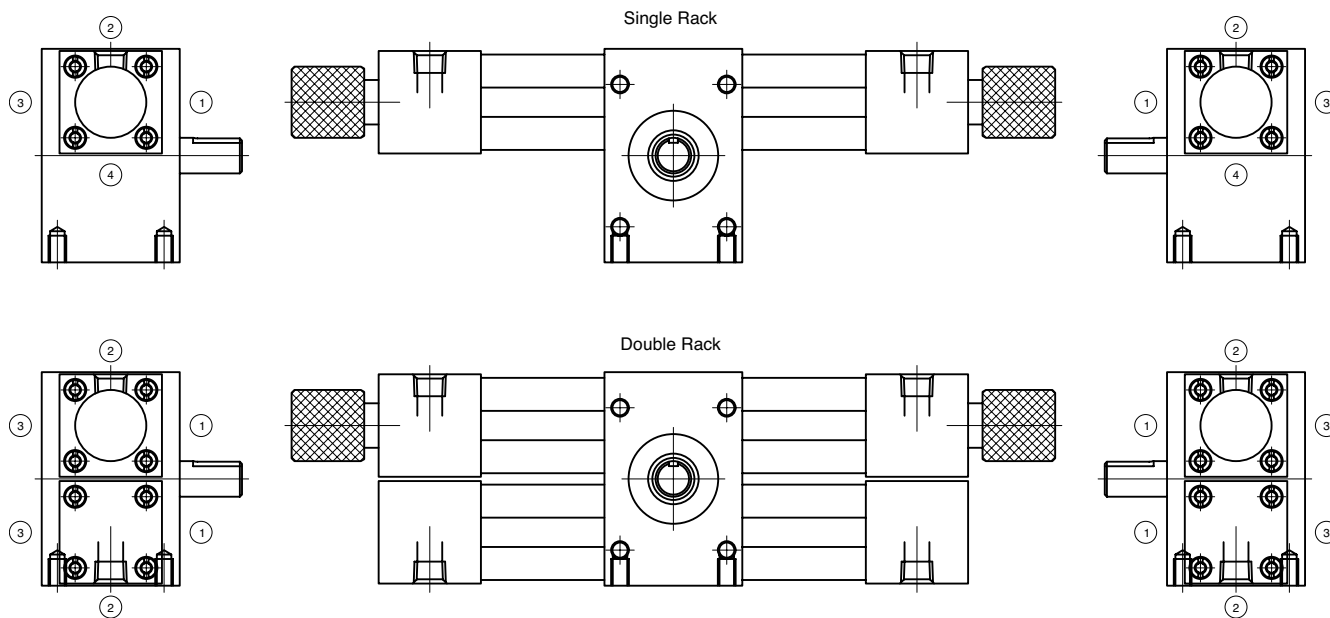

Standard port location is position 1. Standard cushion location is position 2. Ports and/or cushions in position 4 are only available on single rack rotary actuators.

Bore Size	Port Size			
	1/8	1/4	3/8	1/2
1"	S	A	-	-
1 1/2"	A	S	A	-
2"	A	S	A	-
2 1/2"	A	S	A	-
3 1/4"	A	A	S	A

S=Standard
A=Available

Dimensions: Inches

Multi-position Rotary Actuator

3 Position

Our rotary actuators are available in various multi-position configurations. The following shows 3, 4 and 5 position types. Consult factory for additional configurations.

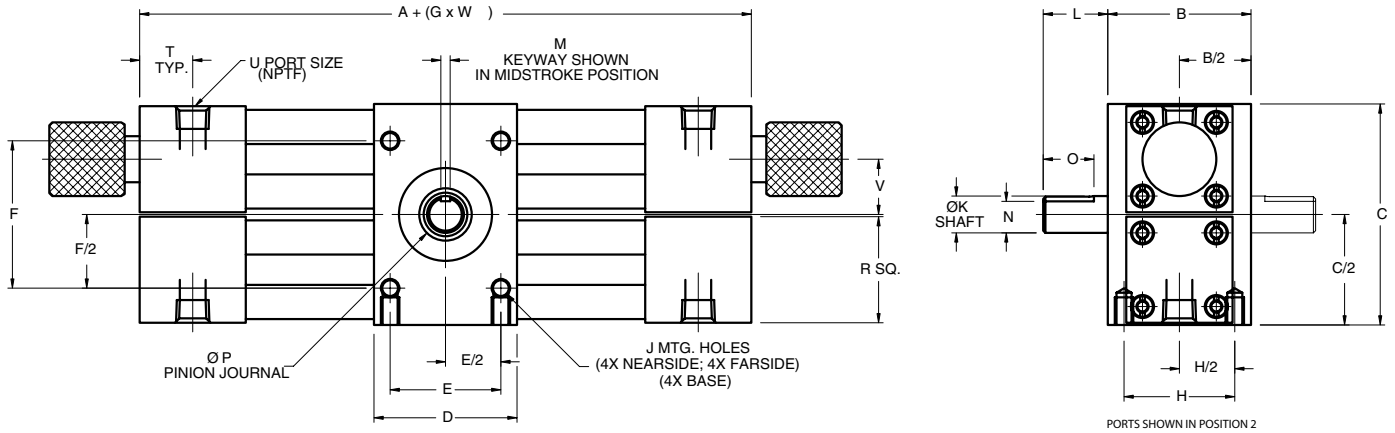

Bore	A	B	C	D	E	F	G	H	J	K	L	M	N	O	P	R	T	U	V
1"	7.50	2.00	3.00	2.00	1.50	2.00	0.01746	1.50	1/4-20 X 3/8 DEEP	.500/.499	0.88	.125/.127	.430/.425	0.63	0.59	1.44	0.75	1/8	0.75
1 1/2"	8.50	3.00	4.25	3.00	2.00	3.00	0.02328	2.00	5/16-18 X 1/2 DEEP	.875/.874	1.88	.188/.190	.771/.761	1.50	0.98	2.00	0.75	1/4	1.13
2"	9.50	3.00	5.00	4.00	2.50	3.50	0.03124	2.00	3/8-16 X 1/2 DEEP	1.125/1.124	1.88	.250/.252	.986/.976	1.50	1.18	2.44	0.75	1/4	1.25
2 1/2"	9.75	3.50	6.00	4.00	2.50	4.50	0.03926	2.00	1/2-13 X 3/4 DEEP	1.375/1.374	2.25	.313/.315	1.201/1.191	1.75	1.57	2.94	0.75	1/4	1.50
3-1/4"	11.25	5.00	8.00	5.00	3.00	5.00	0.04800	2.50	3/4-10 X 1 DEEP	1.750/1.749	3.50	.375/.377	1.542/1.532	3.00	1.77	3.75	0.88	3/8	1.94

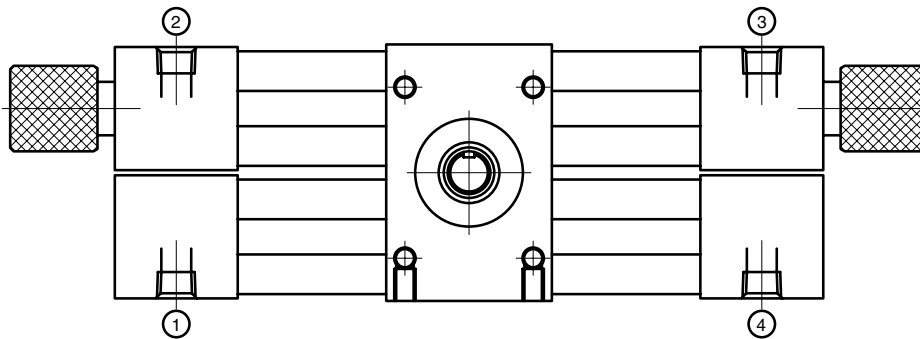

A three position rotary actuator provides one intermediate stopping position between the full counterclockwise and full clockwise position. The full counterclockwise position is achieved by pressurizing port 1. The intermediate position is achieved by pressurizing both ports 2 and 3. The final clockwise position is achieved by pressurizing port 4. Rotation adjustment for the full counterclockwise and full clockwise positions only are standard.

Dimensions: Inches

4 Position

W° = Full Rotation

X° = First Intermediate Rotation

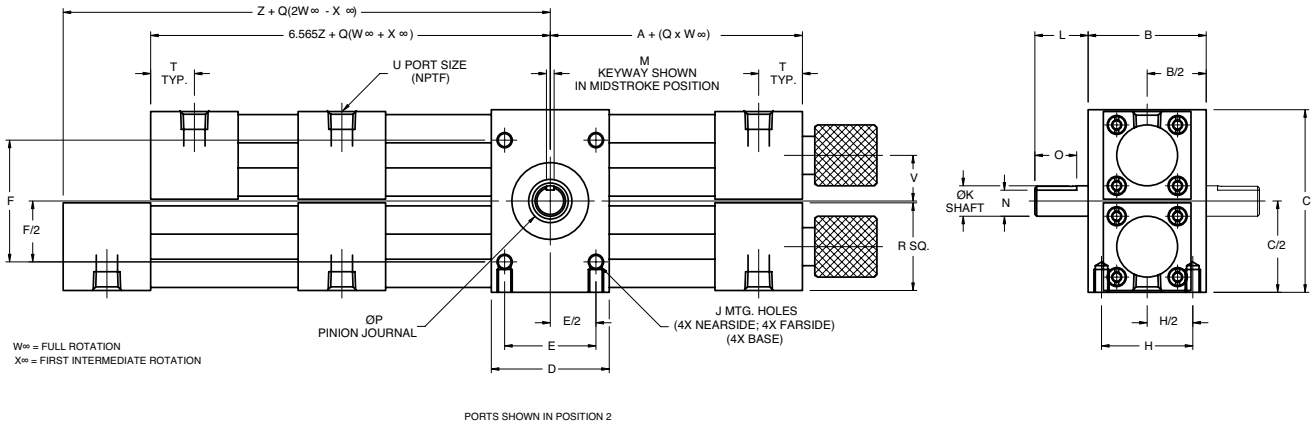

Bore	A	B	C	D	E	F	H	J	K	L
1"	3.75	2.00	3.00	2.00	1.50	2.00	1.50	1/4-20 X 3/8 DEEP	.500/.499	0.88
1 1/2"	4.25	3.00	4.25	3.00	2.00	3.00	2.00	5/16-18 X 1/2 DEEP	.875/.874	1.88
2"	4.75	3.00	5.00	4.00	2.50	3.50	2.00	3/8-16 X 1/2 DEEP	1.125/1.124	1.88
2 1/2"	4.88	3.50	6.00	4.00	2.50	4.50	2.00	1/2-13 X 3/4 DEEP	1.375/1.374	2.25
3 1/4"	5.63	5.00	8.00	5.00	3.00	5.00	2.50	3/4-10 X 1 DEEP	1.750/1.749	3.50

M	N	O	P	Q	R	T	U	V	Z
.125/.127	.430/.425	0.63	0.59	0.00872	1.44	0.75	1/8	0.75	6.405
.188/.190	.771/.761	1.50	0.98	0.01164	2.00	0.75	1/4	1.13	6.904
.250/.252	.986/.976	1.50	1.18	0.01571	2.44	0.75	1/4	1.25	7.407
.313/.315	1.201/1.191	1.75	1.57	0.01963	2.94	0.75	1/4	1.50	7.655
.375/.377	1.542/1.532	3.00	1.77	0.02400	3.75	0.88	3/8	1.94	8.660

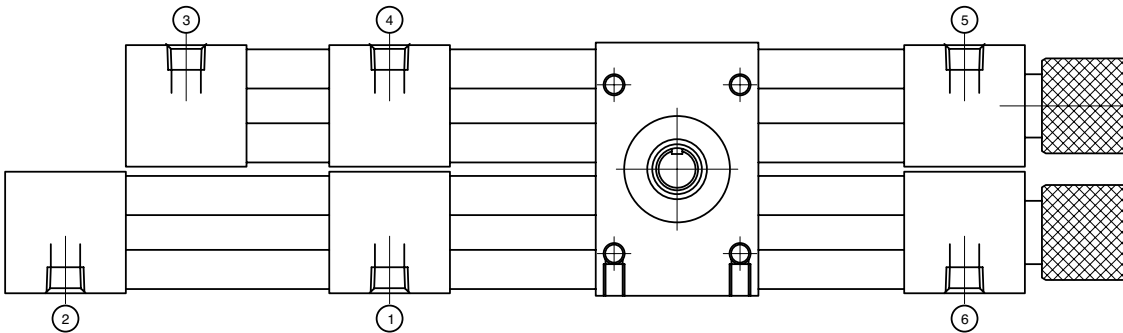

A four position rotary actuator provides two intermediate stopping positions between the full counterclockwise and full clockwise positions. The full counterclockwise position is achieved by pressurizing port 1. The first intermediate position is achieved by pressurizing both ports 2 and 3. The second intermediate position is achieved by pressurizing both ports 4 and 5. The final position is achieved by pressurizing port 6. Rotation adjustment for the full counterclockwise and full clockwise positions only are standard.

Dimensions: Inches

5 Position

W° = Full Rotation

X° = First Intermediate Rotation

Y° = Third Intermediate Rotation

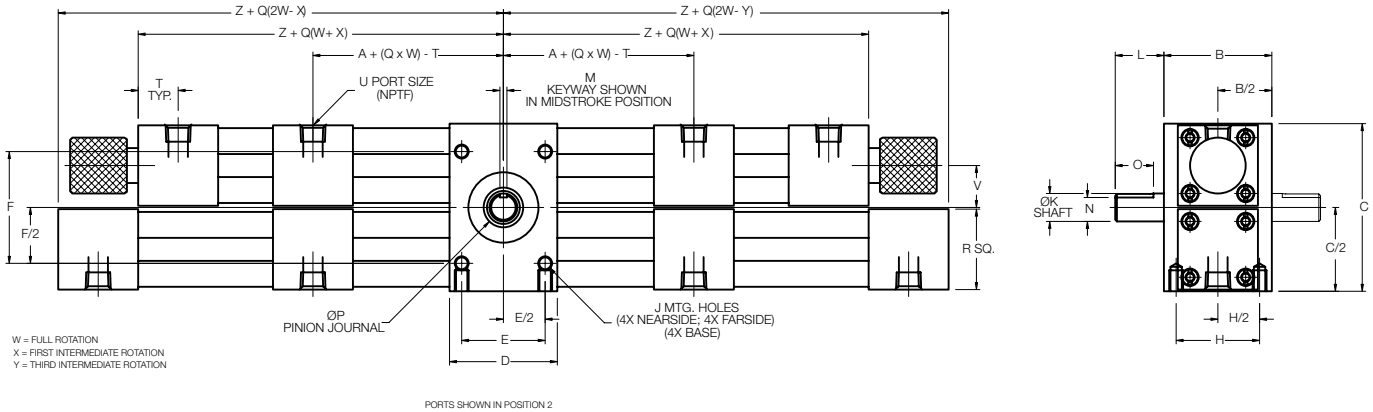

Bore	A	B	C	D	E	F	H	J	K	L
1"	3.75	2.00	3.00	2.00	1.50	2.00	1.50	1/4-20 X 3/8 DEEP	.500/.499	0.88
1 1/2"	4.25	3.00	4.25	3.00	2.00	3.00	2.00	5/16-18 X 1/2 DEEP	.875/.874	1.88
2"	4.75	3.00	5.00	4.00	2.50	3.50	2.00	3/8-16 X 1/2 DEEP	1.125/1.124	1.88
2 1/2"	4.88	3.50	6.00	4.00	2.50	4.50	2.00	1/2-13 X 3/4 DEEP	1.375/1.374	2.25
3 1/4"	5.63	5.00	8.00	5.00	3.00	5.00	2.50	3/4-10 X 1 DEEP	1.750/1.749	3.50

M	N	O	P	Q	R	T	U	V	Z
.125/.127	.430/.425	0.63	0.59	0.00872	1.44	0.75	1/8	0.75	6.405
.188/.190	.771/.761	1.50	0.98	0.01164	2.00	0.75	1/4	1.13	6.904
.250/.252	.986/.976	1.50	1.18	0.01571	2.44	0.75	1/4	1.25	7.407
.313/.315	1.201/1.191	1.75	1.57	0.01963	2.94	0.75	1/4	1.50	7.655
.375/.377	1.542/1.532	3.00	1.77	0.02400	3.75	0.88	3/8	1.94	8.660

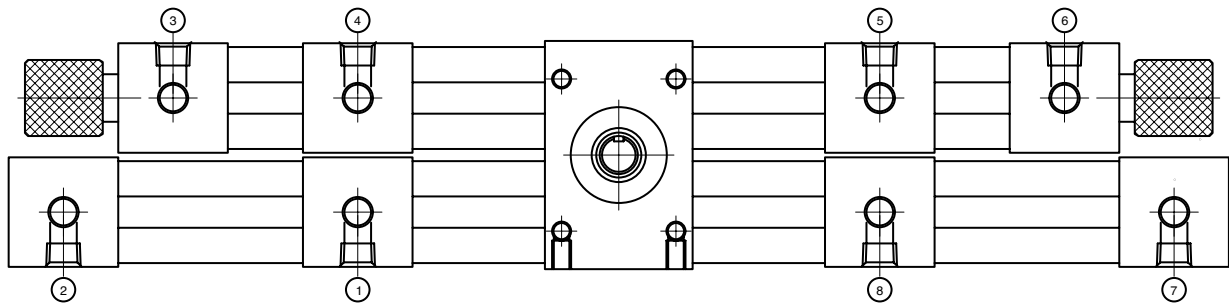

A five position rotary actuator provides three intermediate stopping positions between the full counterclockwise and full clockwise positions. The full counterclockwise position is achieved by pressurizing port 1. The first intermediate position is achieved by pressurizing both ports 2 and 3. The second intermediate position is achieved by pressurizing both ports 4 and 5. The third intermediate position is achieved by pressurizing both ports 6 and 7. The final clockwise position is achieved by pressurizing port 8. Rotation adjustment for the full counterclockwise and full clockwise positions only are standard.

R Series Rotary (Profile)

Bore	Bracket P/N
1"	N99-1185
1 1/2"	N99-1185
2"	N99-1185
2 1/2"	N99-1185

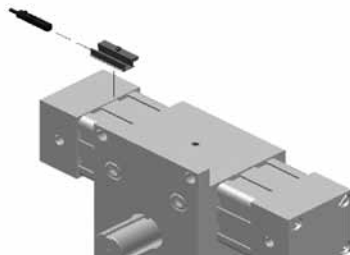

Sensor Description	Standard Cord Set	Quick Disconnect
Reed Switch	REED-FL2-00	REED-QDS-M8U
Hall PNP	PNP-FL2-00-U	PNP-QDS-M8-U
Hall NPN	NPN-FL2-00-U	NPN-QDS-M8-U

See page 15, 16, & 17 for sensor specifications

R Series (Tie Rod)

Bore	Bracket P/N
3 1/4"	N99-1182



Sensing Part Numbers

PNP-FL2-00-U

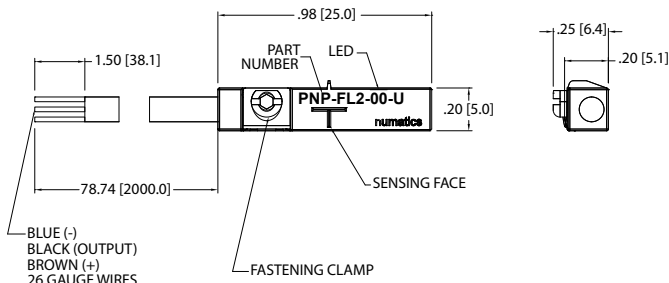

PNP-QDS-M8-U

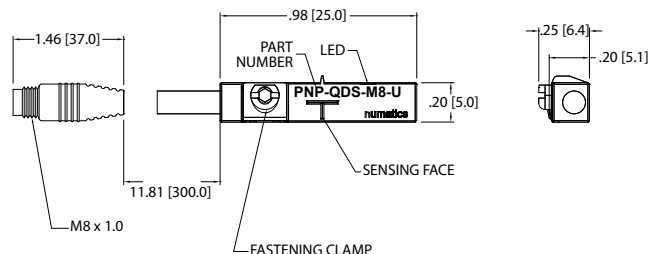

ELECTRICAL DESIGN	DC PNP
OUTPUT	Normally Open
OPERATING VOLTAGE	10-30 VDC
CURRENT RATING	100 mA
SHORT-CIRCUIT PROTECTION	Yes
OVERLOAD PROTECTION	Yes
REVERSE POLARITY PROTECTION	Yes
VOLTAGE DROP	< 2.5 V
CURRENT CONSUMPTION	< 12 mA
REPEATABILITY	< .2mm
POWER-ON DELAY TIME	< 30 ms
SWITCH FREQUENCY	> 3000 Hz
AMBIENT TEMPERATURE	-25°C to 85°C
PROTECTION	IP 67, III
HYSTERESIS	1.0mm
MAGNETIC SENSITIVITY	2.0 mT
TRAVEL SPEED	> 10 m/s
HOUSING MATERIAL	PA (Polyamide) Black; Fastening Clamp: Stainless Steel
FUNCTION DISPLAY SWITCHING STATUS	Yellow LED
CONNECTION	Flying Leads, Pur Cable (2m Long, 3 x26 Gauge Wire)
REMARKS	Clamping Screw with Combined Slot/Hexagon Socket Head AF 1.5 cULus - Class 2 Source Required
ACCESSORIES	Rubber Placeholder, Cable Clip, and Cut Sheet To Be Provided with Every Switch
AGENCY APPROVALS	

ELECTRICAL DESIGN	DC PNP
OUTPUT	Normally Open
OPERATING VOLTAGE	10-30 VDC
CURRENT RATING	100 mA
SHORT-CIRCUIT PROTECTION	Yes
OVERLOAD PROTECTION	Yes
REVERSE POLARITY PROTECTION	Yes
VOLTAGE DROP	< 2.5 V
CURRENT CONSUMPTION	< 12 mA
REPEATABILITY	< .2mm
POWER-ON DELAY TIME	< 30 ms
SWITCH FREQUENCY	> 3000 Hz
AMBIENT TEMPERATURE	-25°C to 85°C
PROTECTION	IP 67, III
HYSTERESIS	1.0mm
MAGNETIC SENSITIVITY	2.0 mT
TRAVEL SPEED	> 10 m/s
HOUSING MATERIAL	PA (Polyamide) Black; Fastening Clamp: Stainless Steel
FUNCTION DISPLAY SWITCHING STATUS	Yellow LED
CONNECTION	M8 Connector (Snap Fit) , Pur Cable (.3 m)
REMARKS	Clamping Screw with Combined Slot/Hexagon Socket Head AF 1.5 cULus - Class 2 Source Required
ACCESSORIES	Rubber Placeholder, Cable Clip, and Cut Sheet To Be Provided with Every Switch
AGENCY APPROVALS	

*Switches are not designed for wet environments. Please see your distributor for additional information.

Sensing Part Numbers

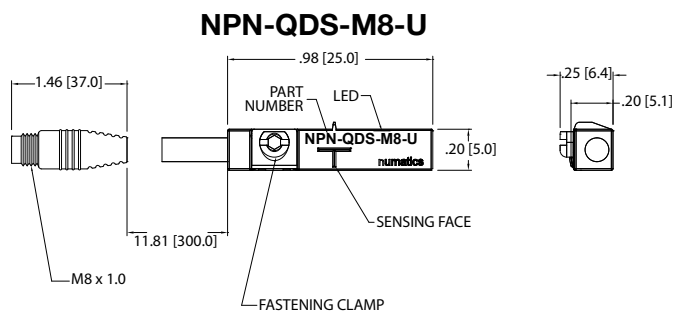
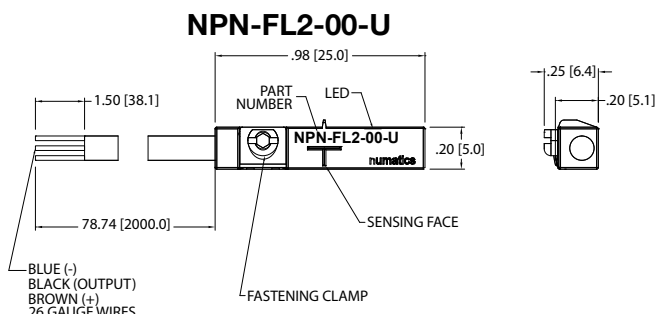

ELECTRICAL DESIGN	DC NPN
OUTPUT	Normally Open
OPERATING VOLTAGE	10-30 VDC
CURRENT RATING	100 mA
SHORT-CIRCUIT PROTECTION	Yes
OVERLOAD PROTECTION	Yes
REVERSE POLARITY PROTECTION	Yes
VOLTAGE DROP	< 2.5 V
CURRENT CONSUMPTION	< 12 mA
REPEATABILITY	< .2mm
POWER-ON DELAY TIME	< 30 ms
SWITCH FREQUENCY	> 3000 Hz
AMBIENT TEMPERATURE	-25°C to 85°C
PROTECTION	IP 67, III
HYSTERESIS	1.0mm
MAGNETIC SENSITIVITY	2.0 mT
TRAVEL SPEED	> 10 m/s
HOUSING MATERIAL	PA (Polyamide) Black; Fastening Clamp: Stainless Steel
FUNCTION DISPLAY SWITCHING STATUS	Yellow LED
CONNECTION	Flying Leads, Pur Cable (2m Long, 3 x26 Gauge Wire)
REMARKS	Clamping Screw with Combined Slot/Hexagon Socket Head AF 1.5 cULus - Class 2 Source Required
ACCESSORIES	Rubber Placeholder, Cable Clip, and Cut Sheet To Be Provided with Every Switch
AGENCY APPROVALS	CE cUL US RoHS

ELECTRICAL DESIGN	DC NPN
OUTPUT	Normally Open
OPERATING VOLTAGE	10-30 VDC
CURRENT RATING	100 mA
SHORT-CIRCUIT PROTECTION	Yes
OVERLOAD PROTECTION	Yes
REVERSE POLARITY PROTECTION	Yes
VOLTAGE DROP	< 2.5 V
CURRENT CONSUMPTION	< 12 mA
REPEATABILITY	< .2mm
POWER-ON DELAY TIME	< 30 ms
SWITCH FREQUENCY	> 3000 Hz
AMBIENT TEMPERATURE	-25°C to 85°C
PROTECTION	IP 67, III
HYSTERESIS	1.0mm
MAGNETIC SENSITIVITY	2.0 mT
TRAVEL SPEED	> 10 m/s
HOUSING MATERIAL	PA (Polyamide) Black; Fastening Clamp: Stainless Steel
FUNCTION DISPLAY SWITCHING STATUS	Yellow LED
CONNECTION	M8 Connector (Snap Fit) , Pur Cable (.3 m)
REMARKS	Clamping Screw with Combined Slot/Hexagon Socket Head AF 1.5 cULus - Class 2 Source Required
ACCESSORIES	Rubber Placeholder, Cable Clip, and Cut Sheet To Be Provided with Every Switch
AGENCY APPROVALS	CE cUL US RoHS

*Switches are not designed for wet environments. Please see your distributor for additional information.

Sensing Part Numbers

REED-FL2-00

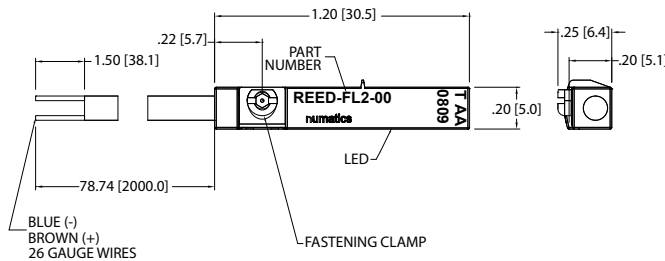

REED-QDS-M8U

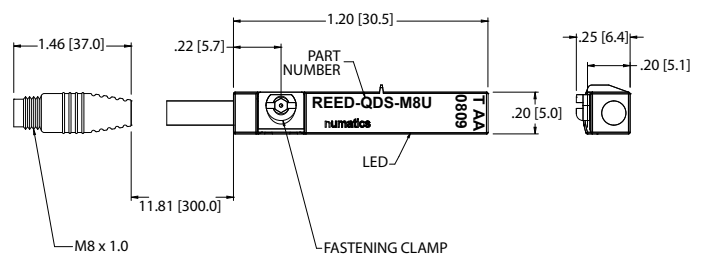

ELECTRICAL DESIGN	AC/DC REED
OUTPUT	Normally Open
OPERATING VOLTAGE	5-120 VAC/DC
CURRENT RATING	100 mA*
SHORT-CIRCUIT PROTECTION	No
OVERLOAD PROTECTION	No
REVERSE POLARITY PROTECTION	Yes
VOLTAGE DROP	< 5 V
REPEATABILITY	± .2mm
MAKETIME INCLUDING BOUNCE	< .6 ms
BREAKTIME	< .1 ms
SWITCHING POWER (MAX)	5 W
SWITCH FREQUENCY	1000 Hz
AMBIENT TEMPERATURE	-25°C to 70°C
PROTECTION	IP 67, II
HYSTERESIS	.9mm
HOUSING MATERIAL	PA (Polyamide) Black; Fastening Clamp: Stainless Steel
FUNCTION DISPLAY SWITCHING STATUS	Yellow LED
CONNECTION	Flying Leads, Pur Cable (2m Long, 2 x26 Gauge Wire)
REMARKS	*External Protective Circuit for Inductive Load (Valve, Contactor, Etc..) Necessary. Conforms to 2008 NEC Section 725 III, Class 2 Circuits Clamping Screw with Combined Slot/Hexagon Socket Head AF 1.5. No LED Function in case of Polarity in DC Operation
ACCESSORIES	Rubber Placeholder, Cable Clip, and Cut Sheet To Be Provided with Every Switch
AGENCY APPROVALS	 RoHS

ELECTRICAL DESIGN	AC/DC REED
OUTPUT	Normally Open
OPERATING VOLTAGE	*5-60 VDC / 5-50 VAC
CURRENT RATING	100 mA
SHORT-CIRCUIT PROTECTION	No
OVERLOAD PROTECTION	No
REVERSE POLARITY PROTECTION	Yes
VOLTAGE DROP	< 5 V
REPEATABILITY	± .2mm
MAKETIME INCLUDING BOUNCE	< .6 ms
BREAKTIME	< .1 ms
SWITCHING POWER (MAX)	5 W
SWITCH FREQUENCY	1000 Hz
AMBIENT TEMPERATURE	-25°C to 70°C
PROTECTION	IP 67, II
HYSTERESIS	.9mm
HOUSING MATERIAL	PA (Polyamide) Black; Fastening Clamp: Stainless Steel
FUNCTION DISPLAY SWITCHING STATUS	Yellow LED
CONNECTION	M8 Connector (Snap Fit), Pur Cable (.3m)
REMARKS	*External Protective Circuit for Inductive Load (Valve, Contactor, Etc..) Necessary. Conforms to 2008 NEC Section 725 III, Class 2 Circuits M8 Connector voltage limited to 5-60 vdc / 5-50 vac to conform with 2008 IEC 61076-2-104 Clamping Screw with Combined Slot/Hexagon Socket Head AF 1.5. No LED Function in case of Polarity in DC Operation
ACCESSORIES	Rubber Placeholder, Cable Clip, and Cut Sheet To Be Provided with Every Switch
AGENCY APPROVALS	 RoHS

*Switches are not designed for wet environments. Please see your distributor for additional information.

Quick Disconnect Cables

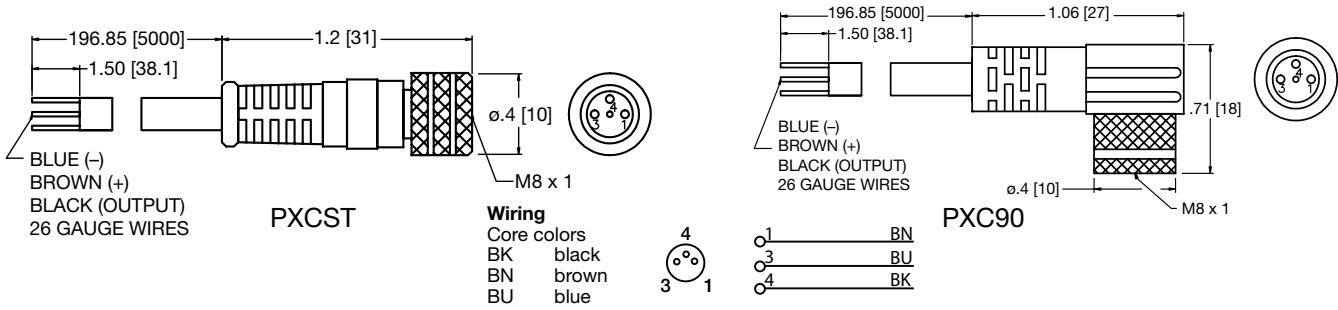

Order Code	Type	Operating Voltage	Current Rating	Cable Material	Protection	Connector
PXCST	Straight 5 m Cable (3 x 26 Gauge wire)	60 AC/75 DC	3 A	PUR	IP 68, III	M8
PXC90	90° 5 m Cable (3 x 26 Gauge wire)	60 AC/75 DC	3 A	PUR	IP 68, III	M8

R Series World Switch Hall Effect Part Numbers

P/N	Switch Style	Electrical Design	Output	Operating Voltage	Current Rating	Switching Power	Voltage Drop	NEMA IP Rating	Temperature Rating
SH6-031	Flying Lead	DC PNP	Normally Open	6-24 VDC	0.3 Amps Max.	7.2 Watts Max.	.5 Volts	NEMA 6	-25° to +75° C
SH6-032	Flying Lead	DC PNP	Normally Open	6-24 VDC	0.3 Amps Max.	7.2 Watts Max.	.5 Volts	NEMA 6	-25° to +75° C
SH6-021	M8 Connector	DC NPN	Normally Open	6-24 VDC	0.3 Amps Max.	7.2 Watts Max.	.5 Volts	NEMA 6	-25° to +75° C
SH6-022	M8 Connector	DC NPN	Normally Open	6-24 VDC	0.3 Amps Max.	7.2 Watts Max.	.5 Volts	NEMA 6	-25° to +75° C

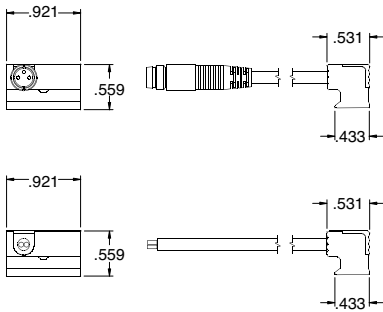

PNP Sourcing

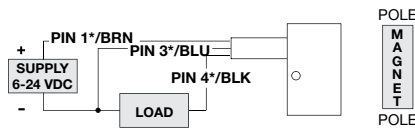

NPN Sinking

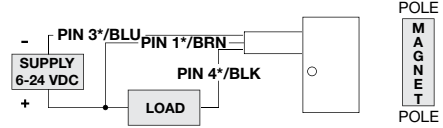



World Class Supplier of Pneumatic Components



World Headquarters

USA Numatics, Incorporated

46280 Dylan Drive
Novi, Michigan 48377

P: 248-596-3200
F: 248-596-3201

Canada Numatics, Ltd

P: 519-758-2700
F: 519-758-5540

Mexico Numatics de Mexico S.A. de C.V.

P: 52-222-284-6176
F: 52-222-284-6179

Brazil Ascoval Ind.e Comercio Ltda

P: (55) 11-4208-1700
F: (55) 11-4195-3970