



Your future's safe!



JANUS

access control safety light curtain

product catalogue

Light curtain ideal for palletizer applications

7-segment display self-diagnosis and light curtain status

External Muting sensors 2 or 4 sensors operating logic

Settings of each function integrally performed via the main connector

Integrated Muting functions

Long range versions up to 80 meters

Patented ML and MT models with Muting sensors built into pre-wired and pre-aligned arms

"L" Logic Crossed beams (one-way)



Suitable solution for any applications of pallet exit.

"L" Logic Parallel beams (one-way)



Suitable solution for transparent material: glass and bottling industry of pallet exit.

"T" Logic Crossed beams (two-way)



Suitable solution for the most common pallet infeed/outfeed applications. Ideal solution in case of a continuous flow of pallets even without separation between the pallets.

"T" Logic Parallel beams (two-way)

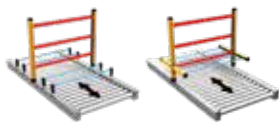

Suitable solution for transparent material and application with presence of a pallet with reduced width or not centred with respect to the conveyor. Through the verification of the 4 sensors, allows to set infinite Muting time-out.

Please note: this configuration needs a separation between two consecutive pallets equal to the distance between the two external Muting sensors.

Models with passive retro-reflector element available

MAIN FEATURES

The Janus Type 4 family of safety light curtains is the ideal solution for the protection of a vast number of high-risk industrial applications, in particular those requiring a high level of integration of the safety functions.

Janus models with built-in Muting function guarantees the independence of the light curtain from the control circuits of the system and, where necessary, also the integration of the Muting sensors.

The features of the Janus range include:

- Settings of each function integrally performed via the main connector
- Integration of the main safety functions, including self-testing of the solid state outputs, external device monitoring (EDM) and the Start/Restart interlock function
- Integration of the Muting function for the MI models and of the Muting sensors for the ML and MT models
- The utmost reliability in the field, thanks to the rugged construction and to the high level of immunity to external interference (optical, EMC, etc.)



Operating temperature: 10 ... +55 °C



IP65 protection rate

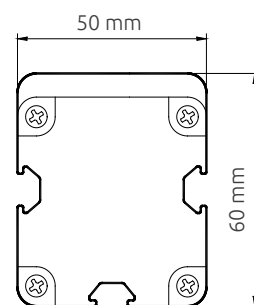

1:2 scale

THE JANUS RANGE

JANUS M - BUILT-IN MUTING FUNCTION



JANUS MI SERIES

The MI series features dedicated connections for connecting external Muting sensors of any type such as photocells, proximity sensors, limit switches, etc.; it can manage the Muting function in both two-way and one-way mode.

A wide range of models with protected height from 310 mm to 1810 mm with resolution of 30, 40, 90 mm and models with 2, 3, 4 beams provides the solution to any application problem.

JANUS MI

Operating range selectable:
0 ... 6 m - low range
1 ... 16 m - high range

JANUS MI Long Range

Operating range selectable:
8 ... 30 m - low range
18 ... 60 m - high range



JANUS ML SERIES

The ML series, with 2 or 3 beams for body detection, uses an original system of horizontal arms (one for the emitter and one for the receiver) with built-in pre-wired and pre-aligned photoelectric Muting sensors which do not require any adjustment.

The arms can be adjusted in height in order to create a detection plane that is more or less angled, with the purpose to achieve correct and constant detection of the material in transit and therefore reliable operation of the protection system.

This ensures the maximum speed and simplicity of installation. The ML series manages the Muting function in one-way mode and is particularly suitable for protecting the outfeed gates of palletizing systems.

JANUS ML

Built-in Muting sensors with crossed beams
Operating range: 1 ... 2,5 m

JANUS ML S2

Special models for the correct detection of transparent object.
Built-in Muting sensors with parallel beams
Operating range: 0 ... 2 m



JANUS MT SERIES

The MT series features four horizontal arms (two for the emitter and two for the receiver) with built-in pre-wired and pre-aligned photoelectric Muting sensors that do not require any adjustment.

The MT series manages the Muting function in two-way mode for the protection of the infeed/outfeed gates in palletizing systems.

JANUS MT

Built-in Muting sensors with crossed beams
Operating range: 0 ... 2,5 m

JANUS MT S4

The MT series also includes MT S4 special models for the correct detection of transparent objects.
Built-in Muting sensors with parallel beams
Operating range: 0 ... 2 m

JANUS M TRX - BUILT-IN MUTING FUNCTION AND PASSIVE RETRO-REFLECTOR ELEMENT

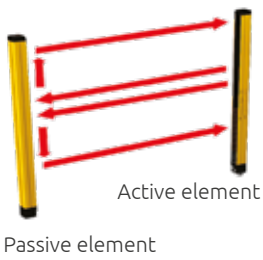

JANUS MI TRX and TRXL SERIES

Janus MI TRX and MI TRXL is composed of an active element and of a passive retro-reflector element requiring no wiring.

It features dedicated connections for connecting external Muting sensors of any type such as photocells, proximity sensors, limit switches, etc. The MI series can manage the Muting function in both two-way and one-way mode.

Models with 2, 3, 4 beams provide the solution to any application problem in access control.

JANUS MI TRX

2 or 4 external sensors
Operating range: 0 ... 6 m

JANUS MI TRX L

2 external sensors - Single connector for all connections
Operating range: 0 ... 6 m



JANUS ML TRX, ML TRX G and ML TRX V SERIES

Also this series uses an original system of horizontal arms (one for the emitter and one for the receiver) with built-in, pre-wired and pre-aligned, photoelectric Muting sensors which do not require any adjustment.

Both the light grid and the sensor arms are composed of an active, emitter/receiver element and of a passive, retro-reflector element, requiring no wiring.

The ML TRX series manages the Muting function in one-way mode and is particularly suitable for protecting the outfeed gates of palletizing systems.

JANUS ML TRX

Operating range: 0 ... 3,5 m

JANUS ML TRX G

Glass models with special built-in Muting sensors to optimise correct and consistent detection of glass and transparent materials in general.
Operating range: 0 ... 2 m

JANUS ML TRX V

Models with longer built-in Muting arms available for high-speed conveyors.
Operating range: 0 ... 3,5 m

JANUS ML TRX GV

Model that integrates both the characteristics of the previous: TRX G (glass models) and TRX V (high-speed conveyors).
Operating range: 0 ... 2 m

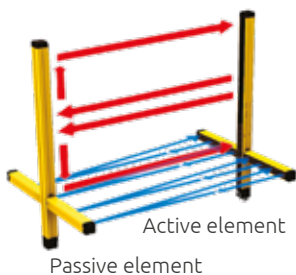

JANUS MT TRX, MT TRX G and MT TRX V SERIES

Janus MT TRX and MT TRX G features four horizontal arms (two for the emitter and two for the receiver) with built-in pre-wired and pre-aligned photoelectric Muting sensors that do not require any adjustment.

Both the light grid and the sensor arms are composed of an active, emitter/receiver element and of a passive, retro-reflector element, requiring no wiring.

The MT TRX series manages the Muting function in two-way mode for the protection of the infeed/outfeed gates in palletizing systems.

JANUS MT TRX

Operating range: 0 ... 3,5 m

JANUS MT TRX G

Glass models with special built-in Muting sensors to optimise correct and consistent detection of glass and transparent materials in general.
Operating range: 0 ... 2 m

JANUS MT TRX V

Models with longer built-in Muting arms available for high-speed conveyors
Operating range: 0 ... 3,5 m

JANUS MT TRX GV

Model that integrates both the characteristics of the previous: TRX G (glass models) and TRX V (high-speed conveyors).
Operating range: 0 ... 2 m



JANUS MM TRX

Janus MM TRX is a modular system with 2, 3 and 4 beams which permits to add pre-wired Muting arms in order to get either a ML TRX (one-way) or a MT TRX (two-way) model with a few simple steps. SL TRX and ST TRX are the pre-wired Muting arms and can be ordered separately.

Janus MM TRX can also be used with external Muting sensors, with 2 or 4 sensors logic.

Muting logics for models MM TRX are:

- one-way (only exit), together with SL TRX
- two-way (two-way) together with SL TRX and ST TRX

Operating range: 0 ... 6 m (0 ... 3,5 m if used with SL TRX and ST TRX).

JANUS J - BUILT-IN CONTROL FUNCTIONS



JANUS J

Models with 2, 3, 4 beams.

JANUS J - LR and LR M12

Long Range models with 2, 3, 4 beams and models with 40 mm resolution and protected height from 610 to 1210 mm.

Long Range models with 2, 3 and 4 beams are also available in M12 version with a M12 8-pole connector for the receiver.

JANUS J LRH M12, J LRH M12 ILP

Long Range models with 2, 3 and 4 beams and M12 connector.

ILP version with integrated laser pointer.

JANUS J

Operating range selectable:
0 ... 6 m - low range
1 ... 16 m - high range

JANUS J - LR, JANUS J LR M12

Operating range selectable:
0 ... 6 m - low range
1 ... 16 m - high range

JANUS J LRH M12

Operating range selectable:
8 ... 30 m - low range
18 ... 60 m - high range

JANUS J LRH M12 ILP

Operating range selectable:
18 ... 40 m - low range
25 ... 80 m - high range

JANUS J TRX - BUILT-IN CONTROL FUNCTIONS AND PASSIVE RETRO-REFLECTOR ELEMENT

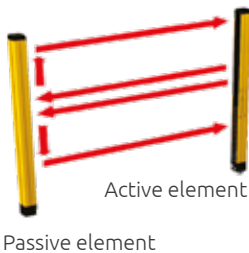

JANUS J TRX, TRXL SERIES

Janus J TRX and J TRXL are safety light grids with 2, 3, 4 beams consisting of an active element (emitter/receiver) and a retro-reflector passive element which does not require electrical connections.

Janus series J TRX and TRXL are the simplest and quickest installation solutions for detection of a person in access control in hazardous areas, and the ideal solutions for all applications in which it is difficult or costly to cable electrical lines.

JANUS J TRX

M12 8-pole connector
Operating range: 0 ... 6 m

JANUS J TRXL

M23 19-pole connector
Operating range: 0 ... 6 m

MUTING TYPES

TWO-WAY MUTING WITH 2 SENSORS



- Max. time between the 2 Muting activation signals: 4 sec
- Possibility of use with photocells, proximity sensors, and limit switches
- Max. Muting time-out time 30 sec. or 90 min. selectable
- Muting enable input available (TRX models only)

Characteristics

- Suitable for the most common pallet infeed/outfeed applications
- Moreover, the TRX models have also the "Muting enable input" function, which starts the Muting sequence only if necessary for the machine cycle, i.e. Muting enabled only when the conveyor is moving

Models: MI - MI TRX - MI TRXL - MM TRX

TWO-WAY SEQUENTIAL MUTING WITH 4 SENSORS



- Max. time between the Muting activation signals: 4 sec. or infinite, selectable
- Possibility to use with photocells, proximity sensors, and limit switches
- Max. Muting time-out time 30 sec. or infinite, selectable
- Muting enable input available (TRX models only)

Characteristics

- Correct Muting sequence even in the presence of pallets with reduced width and/or length or not centred with respect to the conveyor
- Possibility of two-way transit of the pallets and simultaneous protection in the two directions against unauthorised access of personnel
- Moreover, the TRX models have also the "Muting enable input" function, which starts the Muting sequence only if necessary for the machine cycle, i.e. Muting enabled only when the conveyor is moving

Models: MI - MI TRX - MM TRX

ONE-WAY MUTING WITH 2 SENSORS



- Max. time between the 2 Muting activation signals: 4 sec
- Possibility to use with photocells, proximity sensors, and limit switches
- Max. Muting time-out time: 30 sec. or 90 min. selectable

Characteristics

- The light curtain only enables the pallet outfeed
- The Muting function can only be activated from inside the protected zone. No possibility to activate a Muting sequence from the outside
- Elimination of bulk outside the protected area, as the Muting sensors are only present inside the area
- Correct Muting sequence even in the presence of a pallet with reduced width and/or length or not centred with respect to the conveyor
- Moreover, the TRX models have also the "Muting enable input" function, which starts the Muting sequence only if necessary for the machine cycle, i.e. Muting enabled only when the conveyor is moving

Models: MI - MI TRX - MM TRX

ONE-WAY MUTING WITH 2 SENSORS - 2 BUILT-IN MUTING SENSORS WITH CROSSED BEAMS



- Max. time between the 2 Muting activation signals: 4 sec
- Operating range 1 ... 2.5 metres
- Muting sensor elements adjustable in height and angle
- Max. Muting time-out time: 30 sec. or 90 min. selectable
- Versions with 2 or 3 beams

Characteristics

- Reduced installation time and costs
- Sensors positioned in compliance with the regulations regarding the geometry of Muting sensors (IEC TS 62046) and all the other safety parameters; this makes it possible to avoid dangers arising from positioning errors and from possible tampering
- The light curtain only allows pallet outfeed
- The Muting function can only be activated from inside the protected zone. No possibility to activate a Muting sequence from the outside
- Elimination of bulk outside the protected area, as the Muting sensors are only present inside the area
- Correct Muting sequence even in the presence of a pallet with reduced width and/or length or not centred with respect to the conveyor

Models: ML

ONE-WAY MUTING WITH 2 SENSORS - 2 BUILT-IN MUTING SENSORS WITH PARALLEL BEAMS



- Max. time between the 2 Muting activation signals: 4 sec
- Operating range: 0 ... 2 meters for ML S2 and ML TRX G models, 0 ... 3,5 for ML TRX model
- Muting sensor elements adjustable in height and angle
- Max. Muting time-out time: 30 sec. or 90 min. selectable
- Versions with 2 or 3 beams
- Muting enable input available (TRX models only)

Characteristics

- Reduced installation time and costs
- The light curtain only allows pallet outfeed
- The Muting function can only be activated from inside the protected zone. No possibility to activate a Muting sequence from the outside
- Elimination of bulk outside the protected area, as the Muting sensors are only present inside the area
- Correct Muting sequence even in the presence of a pallet with reduced width and/or length or not centred with respect to the conveyor
- ML TRX G models especially designed for transparent material, ideal solution for glass and bottling industry
- ML TRX V models for high-speed conveyors
- ML TRX GV model with both the characteristics of the previous
- Moreover, the TRX models have also the "Muting enable input" function, which starts the Muting sequence only if necessary for the machine cycle, i.e. Muting enabled only when the conveyor is moving

Models: ML S2 - ML TRX - ML TRX G - ML TRX V - ML TRX GV - MM TRX with SL TRX

TWO-WAY MUTING WITH 2 SENSORS - 2 BUILT-IN MUTING SENSORS WITH CROSSED BEAMS



- Max. time between the 2 Muting activation signals: 4 sec.
- Operating range: 1 ... 2.5 metres
- Muting sensor elements adjustable in height and angle
- Max. Muting time-out time: 30 sec. or 90 min. selectable
- Versions with 2 or 3 beams

Characteristics

- Reduced installation time and costs
- Standard solution for the most common pallet infeed/outfeed applications

Models: MT

TWO-WAY SEQUENTIAL MUTING 4 SENSORS - 4 BUILT-IN MUTING SENSORS PARALLEL BEAM



- Max. time between the Muting activation signals: 4 sec. or infinite, selectable
- Operating range: 0 ... 2 meters for MT S4. and 0 ... 3.5 meters for MT TRX models
- Muting sensor elements adjustable in height and angle
- Max. Muting time-out time: 30 sec. or infinite, selectable
- Versions with 2 or 3 beams

Characteristics

- Correct Muting sequence even in the presence of a pallet with reduced width and/or length or not centred with respect to the conveyor
- Possibility of two-way transit of the pallets and simultaneous protection in the two directions against unauthorized access of personnel
- MT TRX G models especially designed for transparent material, ideal solution for glass and bottling industry
- MT TRX V models for high-speed conveyors
- MT TRX GV model with both the characteristics of the previous
- Moreover, the TRX models have also the "Muting enable input" function, which starts the Muting sequence only if necessary for the machine cycle, i.e. Muting enabled only when the conveyor is moving

Models: MT S4 - MT TRX - MT TRX G - MT TRX V - MT TRX GV - MM TRX with SL TRX and ST TRX

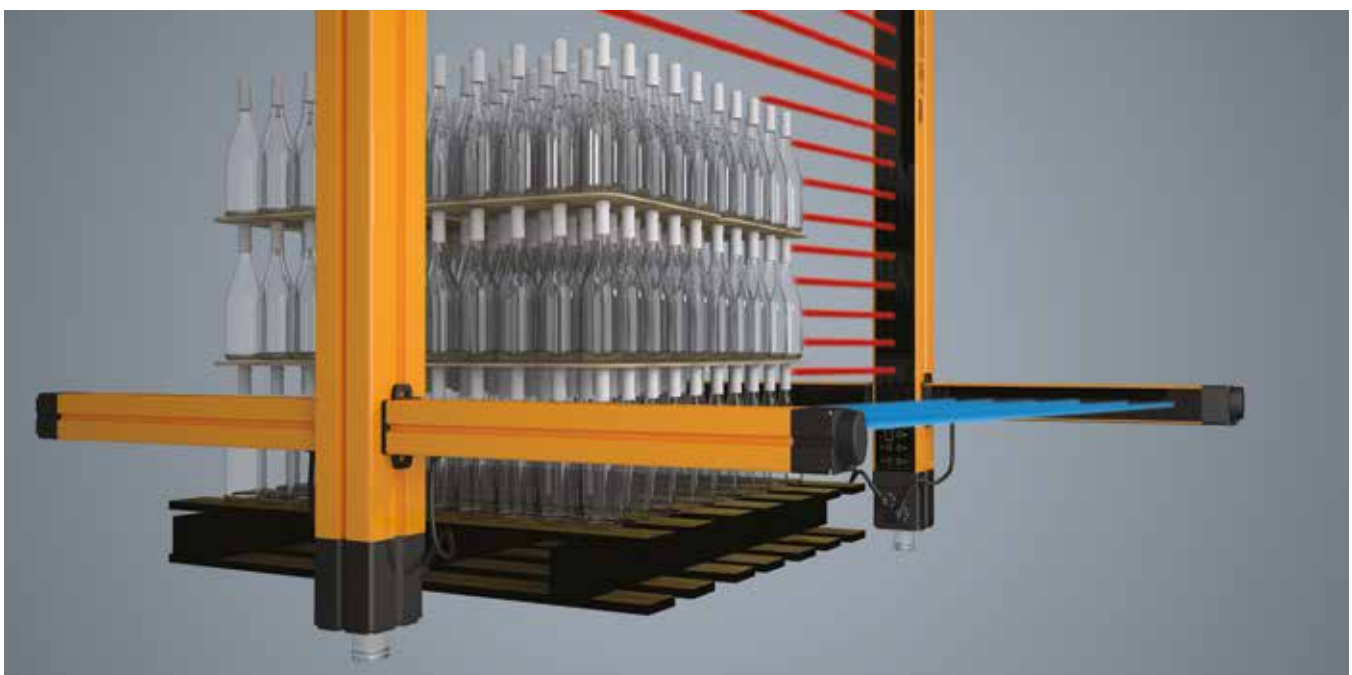

APPROVALS

- 2006/42/EC: "Machine Directive"
- 2014/30/EU: "Electromagnetic Compatibility Directive"
- 2014/35/EU: "Low Voltage Directive"
- EN 61496-1/A1:2013 "Safety of machinery - Electro sensitive protective equipment - General requirements and tests"
- IEC 61496-2:2010 (SIL3) "Safety of machinery - Electro-sensitive protective equipment - Particular requirements for equipment using active opto-electronic protective devices (AOPDs)"
- IEC 61508-1:2010 (SIL3) "Functional safety of electrical/electronic programmable electronic safety related systems - General requirements"
- IEC 61508-2:2010 (SIL3) "Functional safety of electrical/electronic/programmable electronic safety related systems - Requirements for electrical/electronic/programmable electronic safety-related systems".
- IEC 61508-3:2010 (SIL3) "Functional safety of electrical/electronic programmable electronic safety related systems: Software requirements"
- IEC 61508-4:2010 (SIL3) "Functional safety of electrical/electronic programmable electronic safety related systems - Definitions and abbreviations"
- EN ISO 13849-1:2015 (Cat. 4, PL e) "Safety of machinery - Safety-related parts of control systems - Part 1: General principles for design"
- IEC 62061:2005 / A2: 2015 (SILCL3) "Safety of machinery - Functional safety of safety-related electrical, electronic and programmable electronic control systems"
- EN 50178:1997 "Electronic equipment for use in power installations"
- EN 55022:2006 "Information Technology Equipment - Radio Disturbance Characteristics - Limits and Methods of Measurement"
- UL (C+US) mark For USA and Canada
- ANSI / UL 1998: "Safety Software in Programmable Components"
- The mark TS indicates that the product has been approved by the government of Taiwan



NOTE: ML TRX and MT TRX models are quick and easy to install. Also, they are complying with regulatory requirements on Muting sensor geometry and all other safety-related parameters, as per IEC TS 62046 and other current standards.

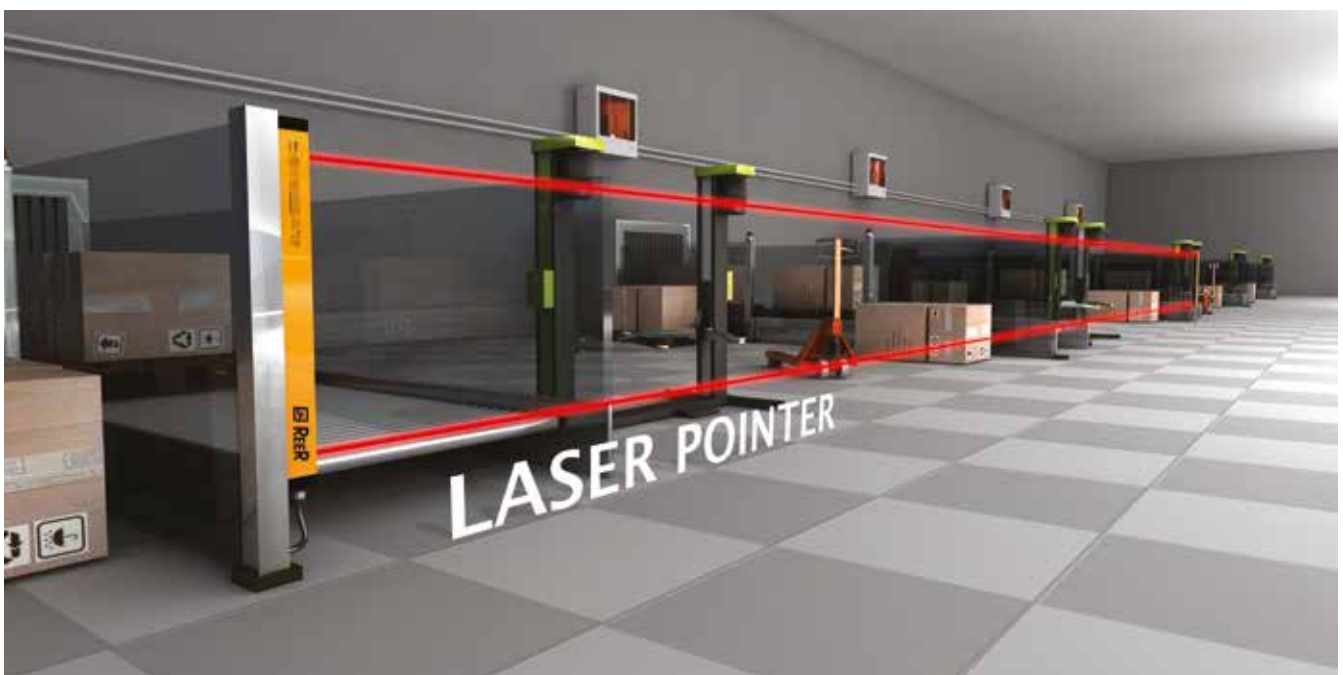



SAFETY LEVEL

TYPE 4

SIL 3 - SILCL 3
PL e - Cat. 4

Resolution (mm)	Start/Restart	Muting logic
30, 40, 90	Manual or Automatic	Two-way One-way
Access control	Safety outputs	Muting sensors
2, 3, 4 beams	2	External 2 or 4

Built-in Muting function in all the models. Ideal for palletizer applications.

Models with front M12 connectors for external Muting sensors, with operating logic with 2 or 4 sensors.

Configuration is carried out via hardware by means of the main connector.

Use of unshielded cables up to 100 m.

MJB connection box for quick connection of the light curtains and providing the main commands necessary for their operation close to the protected gate.

Protected heights:

310 mm ... 1810 mm - Models 40, 90 mm resolution.

310 mm ... 1210 mm - Models 30 mm resolution.



TECHNICAL FEATURES

Max. range (m)	Selectable 6 or 16
Response time (ms)	7 ... 30
Safety outputs	2 PNP auto-controlled - 500 mA at 24 VDC with short-circuit, overload, polarity reversal protection
Light curtain status indication and weak signal output	PNP - 100 mA at 24 VDC
Status display	7-segment display and LEDs for self-diagnosis and light curtain status
Muting lamp output (mandatory)	24 VDC; 0,5 ... 5 W
External Device Monitoring	External device monitoring feedback input with enabling, selectable
Max. Muting time-out	30 sec. or 90 min. selectable (30 sec. or infinite selectable only for models with 4 sensors two-way logic)
Override function	Built-in override function with 2 operating modes, selectable: - manual action with hold to run - automatic with pulse command
Max. override time-out (min.)	15
Power supply (VDC)	24 ± 20%
Muting logic	Two-way with 2 or 4 sensors One-way with 2 sensors
Muting sensors	External Muting sensors with relay or PNP output (dark-on logic)

CABLES NEEDED

- Emitter: M12 5-pole. See [page 48 - 49](#) (CDx, CDx SB, CD9x, CDM9, CDM99)
- Receiver: M23 19-pole. See [page 48](#) (CJx, CJM23)
- Muting sensors: M12 5-pole. See [page 50 - 53](#) (CJ95, CJM9)
- Option - Emitter and MJB connection box. See [page 51](#) (CJBEx)
- Option - Receiver and MJB connection box. See [page 50](#) (CJBRx)

ACCESSORIES

- Safety relay. See [page 46](#)
- Janus SL - Muting sensor elements. See [page 55](#)
- MJB connection box. See [page 47](#)
- Support columns. See [page 58](#)
- Laser alignment device. See [page 61](#)
- Vibration dumpers. See [page 60](#)
- Brackets. See [page 60](#)

CONNECTORS

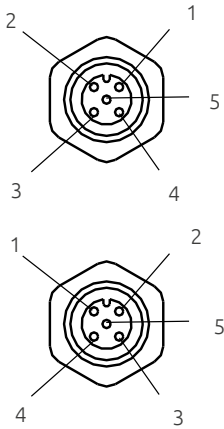

EMITTER
M12 5-pole
1 - 24 VDC
2 - TEST
3 - 0 VDC
4 - NC
5 - PE

MUTING SENSOR
M12-pole
1 - 24 VDC
2 - SENSOR 1/3
3 - 0 VDC
4 - SENSOR 2/4
5 - PE

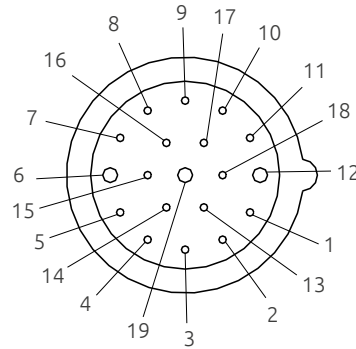
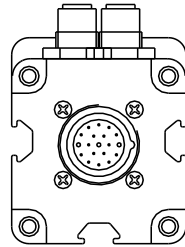

RECEIVER
M23 19-pole
1 - MUT. LAMP
2 - OSSD2 OUT
3 - OSSD1 OUT
4 - STATUS OUT
5 - NC
6 - 0 VDC
7 - CONF0
8 - CONF1
9 - CONF2
10 - CONF3
11 - ENABLE_K IN
12 - PE
13 - MAN/AUTO
14 - RESTART
15 - NC
16 - OVERRIDE1
17 - OVERRIDE2
18 - FEED_K1K2
19 - 24 VDC

PART NUMBERS

Hand detection Max. range: selectable 3 or 6 m



MI Resolution 30 mm	MI 303	MI 453	MI 603	MI 753	MI 903	MI 1053	MI 1203
Ordering codes	1360241	1360242	1360243	1360244	1360245	1360246	1360247
Protected height (mm)	310	460	610	760	910	1060	1210
Number of beams	16	24	32	40	48	56	64
Overall height (mm)	476	626	776	926	1076	1226	1376



MI Resolution 40 mm	MI 304	MI 454	MI 604	MI 754	MI 904	MI 1054	MI 1204	MI 1354	MI 1504	MI 1654	MI 1804
Ordering codes	1360375	1360376	1360377	1360378	1360379	1360380	1360381	1360382	1360383	1360384	1360385
Protected height (mm)	310	460	610	760	910	1060	1210	1360	1510	1660	1810
Number of beams	10	15	20	25	30	35	40	45	50	55	60
Overall height (mm)	476	626	776	926	1076	1226	1376	1526	1676	1826	1976

Body detection Max. range: selectable 3 or 6 m



MI Resolution 90 mm	MI 309	MI 459	MI 609	MI 759	MI 909	MI 1059	MI 1209	MI 1359	MI 1509	MI 1659	MI 1809
Ordering codes	1360541	1360542	1360543	1360544	1360545	1360546	1360547	1360548	1360549	1360550	1360551
Protected height (mm)	310	460	610	760	910	1060	1210	1360	1510	1660	1810
Number of beams	5	7	9	11	13	15	17	19	21	23	25
Overall height (mm)	476	626	776	926	1076	1226	1376	1526	1676	1826	1976

Access control Max. range: selectable 3 or 6 m



MI 2, 3, 4 beams	MI 2B	MI 3B	MI 4B
Ordering codes	1360660	1360661	1360662
Number of beams	2	3	4
Beam spacing (mm)	500	400	300
Protected height (mm)	510	810	910
Overall height (mm)	776	1076	1176

JANUS MI LR

WITH MUTING FUNCTION



SAFETY LEVEL
TYPE 4
 SIL 3 - SILCL 3
 PL e - Cat. 4

Resolution (mm)	Start/Restart	Muting logic
40	Manual or Automatic	Two-way One-way
Access control	Safety outputs	Muting sensors
2, 3, 4 beams	2	External 2 or 4

Built-in Muting function in all the models. Ideal for palletizer applications.

Long Range models with range up to 60 m.

Models with front M12 connectors for external Muting sensors, with operating logic with 2 or 4 sensors.

Configuration is carried out via hardware by means of the main connector.

Use of unshielded cables up to 100 m.

MJB connection box for quick connection of the light curtains and providing the main commands necessary for their operation close to the protected gate.

Protected heights: 776 mm ... 1376 mm.

TECHNICAL FEATURES

Max. range (m)	Selectable 30 or 60
Response time (ms)	7 ... 30
Safety outputs	2 PNP auto-controlled - 500 mA at 24 VDC with short-circuit, overload, polarity reversal protection
Light curtain status indication and weak signal output	PNP - 100 mA at 24 VDC
Status display	7-segment display and LEDs for self-diagnosis and light curtain status
Muting lamp output (mandatory)	24 VDC; 0,5 ... 5 W
External Device Monitoring	External device monitoring feedback input with enabling, selectable
Max. Muting time-out	30 sec. or 90 min. selectable
Override function	Built-in override function with 2 operating modes, selectable: - manual action with hold to run - automatic with pulse command
Max. override time-out (min.)	15
Power supply (VDC)	24 ± 20%
Muting logic	Two-way with 2 or 4 sensors One-way with 2 sensors
Muting sensors	External Muting sensors with relay or PNP output (dark-on logic)

CABLES NEEDED

- Emitter: M12 5-pole. See [page 48 - 49](#) (CDx, CDx SB, CD9x, CDM9, CDM99)
- Receiver: M23 19-pole. See [page 48](#) (CJx, CJM23)
- Muting sensors: M12 5-pole. See [page 50 - 53](#) (CJ95, CJM9)
- Option - Emitter and MJB connection box. See [page 51](#) (CJBEx)
- Option - Receiver and MJB connection box. See [page 50](#) (CJBRx)

ACCESSORIES

- Safety relay. See [page 46](#)
- MJB connection box. See [page 47](#)
- Support columns. See [page 58](#)
- Laser alignment device. See [page 61](#)
- Vibration dumpers. See [page 60](#)
- Brackets. See [page 60](#)



CONNECTORS

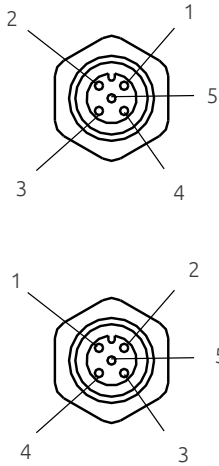

EMITTER
M12 5-pole
1 - 24 VDC
2 - TEST
3 - 0 VDC
4 - NC
5 - PE

MUTING SENSOR
M12 5-pole
1 - 24 VDC
2 - SENSOR 1/3
3 - 0 VDC
4 - SENSOR 2/4
5 - PE

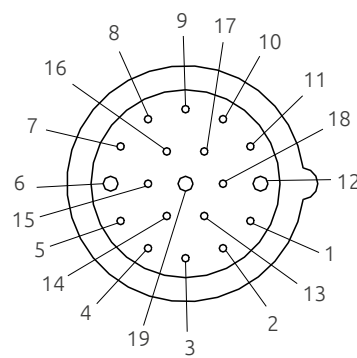
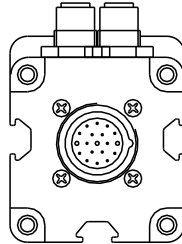

RECEIVER
M23 19-pole
1 - MUT. LAMP
2 - OSSD2 OUT
3 - OSSD1 OUT
4 - STATUS OUT
5 - NC
6 - 0 VDC
7 - CONF0
8 - CONF1
9 - CONF2
10 - CONF3
11 - ENABLE_K IN
12 - PE
13 - MAN/AUTO
14 - RESTART
15 - NC
16 - OVERRIDE1
17 - OVERRIDE2
18 - FEED_K1K2
19 - 24 VDC

PART NUMBERS

Hand detection Max. range: selectable 30 or 60 m



MI Long Range Resolution 40 mm	MI 604 LR	MI 904 LR	MI 1204 LR
Ordering codes	1360388	1360390	1360392
Protected height (mm)	610	910	1210
Number of beams	30	45	60
Overall height (mm)	776	1076	1376

Access control Max. range: selectable 30 or 60 m



MI e MI LR 2, 3, 4 beams	MI 2B LR	MI 3B LR	MI 4B LR
Ordering codes	1360670	1360671	1360672
Number of beams	2	3	4
Beam spacing (mm)	500	400	300
Protected height (mm)	510	810	910
Overall height (mm)	776	1076	1176

JANUS ML

WITH MUTING FUNCTION



Access control	Start/Restart	SAFETY LEVEL
2, 3 beams	Manual or Automatic	TYPE 4
Safety outputs	Muting logic	SIL 3 - SILCL 3 PL e - Cat. 4
2	One-way	Muting sensors
		2 built-in

Built-in Muting function in all the models. Ideal for palletizer applications. Pallet outfeed only.

Muting sensors optoelectronics with 2 crossed or parallel beams built into 2 pre-wired and pre-aligned arms, adjustable in height and angle.

ML S2 models for detection of transparent object. Built-in sensor with parallel beams.

Configuration is carried out via hardware by means of the main connector.

Use of unshielded cables up to 100 m.

MJB connection box for quick connection of the light curtains and providing the main commands necessary for their operation close to the protected gate.

TECHNICAL FEATURES

Operating range (m)	1 ... 2,5 0 ... 2 for ML S2 models
Response time (ms)	7 ... 30
Safety outputs	2 PNP auto-controlled - 500 mA at 24 VDC with short-circuit, overload, polarity reversal protection
Light curtain status indication and weak signal output	PNP - 100 mA at 24 VDC
Status display	7-segment display and LEDs for self-diagnosis and light curtain status
Muting lamp output	24 VDC; 0,5 ... 5 W
External Device Monitoring	External device monitoring feedback input with enabling, selectable
Max. Muting time-out	30 sec. or 90 min. selectable
Override function	Built-in override function with 2 operating modes, selectable: - manual action with hold to run - automatic with pulse command
Max. override time-out (min.)	15
Power supply (VDC)	24 ± 20%
Muting logic	One-way with 2 sensors
Muting sensors	Optoelectronics with 2 crossed or parallel beams (model ML S2). Built-in – pre-aligned – pre-wired, with adjustable height and angle

CABLES NEEDED

- Emitter: M12 5-pole. See [page 48 - 49](#) (CDx, CDx SB, CD9x, CDM9, CDM99)
- Receiver: M23 19-pole. See [page 48](#) (CJ x, CJM23)
- Option - Emitter and MJB connection box. See [page 51](#) (CJBEx)
- Option - Receiver and MJB connection box. See [page 50](#) (CJBRx)

ACCESSORIES

- Safety relay. See [page 46](#)
- MJB connection box. See [page 47](#)
- Support columns. See [page 58](#)
- Laser alignment device. See [page 61](#)
- Vibration dumpers. See [page 60](#)
- Brackets. See [page 60](#)



CONNECTORS

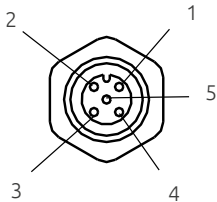

EMITTER
M12 5-pole

- 1 - 24 VDC
- 2 - TEST
- 3 - 0 VDC
- 4 - NC
- 5 - PE

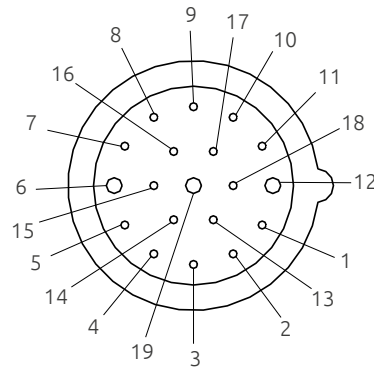
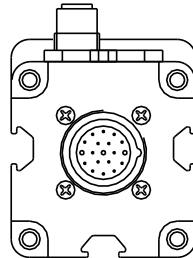

RECEIVER
M23 19-pole

- 1 - MUT. LAMP
- 2 - OSSD2 OUT
- 3 - OSSD1 OUT
- 4 - STATUS OUT
- 5 - NC
- 6 - 0 VDC
- 7 - CONF0
- 8 - CONF1
- 9 - CONF2
- 10 - CONF3
- 11 - ENABLE_K IN
- 12 - PE
- 13 - MAN/AUTO
- 14 - RESTART
- 15 - NC
- 16 - OVERRIDE1
- 17 - OVERRIDE2
- 18 - FEED_K1K2
- 19 - 24 VDC

PART NUMBERS

Access control

Max. range: 2,5 m



ML 2, 3 beams	ML 2B	ML 3B	ML 2B S2	ML 3B S2
Ordering codes	1360020	1360021	1360024	1360025
Number of beams	2	3	2	3
Beam spacing (mm)	500	400	500	400
Protected height (mm)	510	810	510	810
Overall height (mm)	776	1076	776	1076
Muting sensors	2 crossed beams		2 parallel beams	



Access control	Start/Restart	SAFETY LEVEL TYPE 4 SIL 3 - SILCL 3 PL e - Cat. 4
2, 3 beams	Manual or Automatic	
Safety outputs	Muting logic	Muting sensors
2	Two-way	4 built-in

Built-in Muting function in all the models. Ideal for palletizer applications. Pallet infeed and outfeed.

Muting sensors optoelectronics with 2 crossed or 4 parallel beams built into 4 pre-wired and pre-aligned arms, adjustable in height and angle.

MT S4 models for detection of transparent object. Built-in sensor with parallel beams.

Configuration is carried out via hardware by means of the main connector.

Use of unshielded cables up to 100 m.

MJB connection box for quick connection of the light curtains and providing the main commands necessary for their operation close to the protected gate.



TECHNICAL FEATURES

Operating range (m)	1 ... 2,5 0 ... 2 for MT S4 models
Response time (ms)	7 ... 30
Safety outputs	2 PNP auto-controlled - 500 mA at 24 VDC with short-circuit, overload, polarity reversal protection
Light curtain status indication and weak signal output	PNP - 100 mA at 24 VDC
Status display	7-segment display and LEDs for self-diagnosis and light curtain status
Muting lamp output	24 VDC; 0,5 ... 5 W
External Device Monitoring	External device monitoring feedback input with enabling, selectable
Max. Muting time-out	30 sec. or 90 min. selectable 30 sec. or infinite for MT S4 with 4 sensors
Override function	Built-in override function with 2 operating modes, selectable: - manual action with hold to run - automatic with pulse command
Max. override Time-out (min.)	15
Power supply (VDC)	24 ± 20%
Muting logic	Two-way with 2 sensors (models MT) Two-way sequential with 4 sensors (models MT S4)
Muting sensors	Optoelectronics with 2 crossed or 4 parallel beams (model MT S4). Built-in – pre-aligned – pre-wired, with adjustable height and angle

CABLES NEEDED

- Emitter: M12 5-pole. See [page 48 - 49](#) (CDx, CDx SB, CD9x, CDM9, CDM99)
- Receiver: M23 19-pole. See [page 48](#) (CJx, CJM23)
- Option - Emitter and MJB connection box. See [page 51](#) (CJBEx)
- Option - Receiver and MJB connection box. See [page 50](#) (CJBRx)

ACCESSORIES

- Safety relay. See [page 46](#)
- MJB connection box. See [page 47](#)
- Support columns. See [page 58](#)
- Laser alignment device. See [page 61](#)
- Vibration dumpers. See [page 60](#)
- Brackets. See [page 60](#)

CONNECTORS

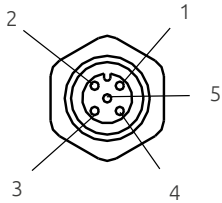

EMITTER
M12 5-pole

- 1 - 24 VDC
- 2 - TEST
- 3 - 0 VDC
- 4 - NC
- 5 - PE

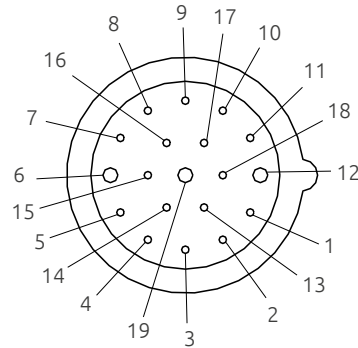
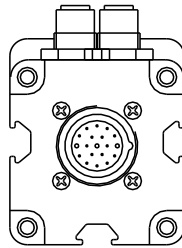

RECEIVER
M23 19-pole

- 1 - MUT. LAMP
- 2 - OSSD2 OUT
- 3 - OSSD1 OUT
- 4 - STATUS OUT
- 5 - NC
- 6 - 0 VDC
- 7 - CONF0
- 8 - CONF1
- 9 - CONF2
- 10 - CONF3
- 11 - ENABLE_K IN
- 12 - PE
- 13 - MAN/AUTO
- 14 - RESTART
- 15 - NC
- 16 - OVERRIDE1
- 17 - OVERRIDE2
- 18 - FEED_K1K2
- 19 - 24 VDC

PART NUMBERS

Access control

Max. range: 2,5 m



MT 2, 3 beams	MT 2B	MT 3B	MT 2B S4	MT 3B S4
Ordering codes	1360030	1360031	1360034	1360035
Number of beams	2	3	2	3
Beam spacing (mm)	500	400	500	400
Protected height (mm)	510	810	510	810
Overall height (mm)	776	1076	776	1076
Muting sensors	2 crossed beams		4 parallel beams	

SENSOR ELEMENT ADJUSTMENT - ML and MT versions

The sensor elements present in all Janus ML and MT versions are adjustable in height and angle.

This important and unique feature enables the inclination of the detection plane of the sensors to obtain correct and constant detection of irregular materials in transit.

Models ML TRX G e MT TRX G (Glass) with special built-in Muting sensors to optimise correct and consistent detection of glass and transparent materials in general.

A reference ruler placed on the side of the barrier facilitates the alignment of the arms.

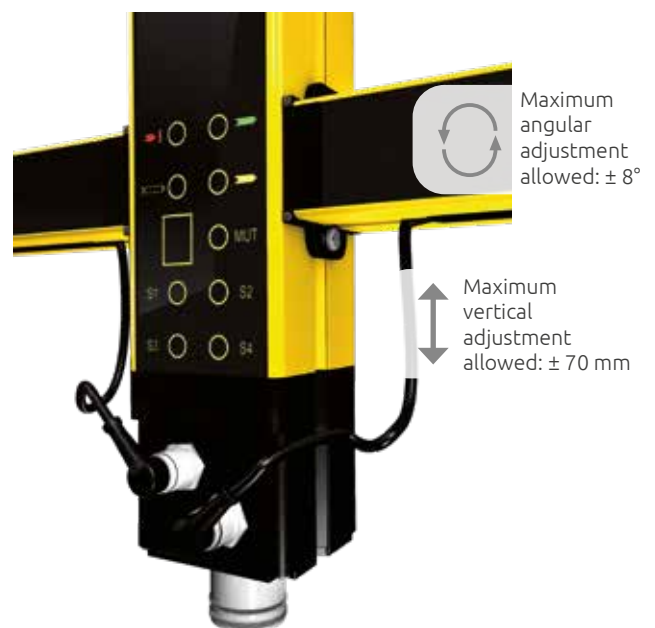

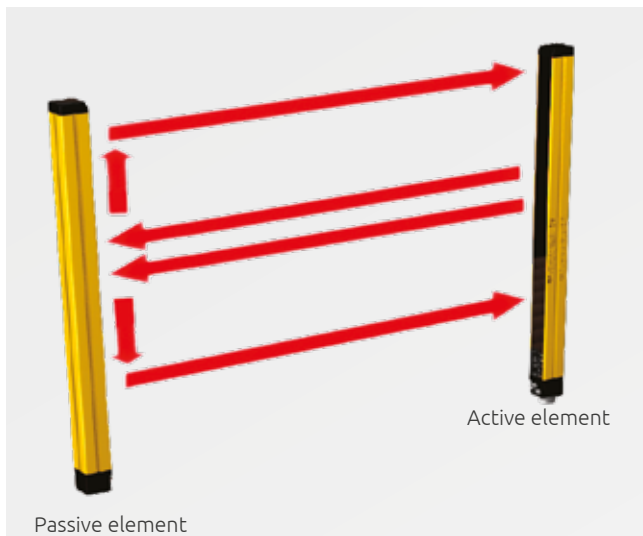

Access control 2, 3, 4 beams	Start/Restart Manual or Automatic	SAFETY LEVEL TYPE 4 SIL 3 - SILCL 3 PL e - Cat. 4
Safety outputs 2	Muting logic Two-way	Muting sensors External 2 or 4

Built-in Muting function in all the models. Ideal for palletizer applications.

Models with passive retro-reflector element.

- MI TRX models with front M12 connectors for external Muting sensors and operating logic with 2 or 4 sensors
- MI TRXL models with single M23 connector and operating logic with 2 sensors

Input Muting enable and Muting state output.

Configuration is carried out via hardware by means of the main connector.

Unshielded cables up to 100 m long are used. MJB connection box for quick connection of the light curtains and providing the main commands necessary for their operation close to the protected gate.

TECHNICAL FEATURES

Max. range (m)	6
Response time (ms)	≤ 10,5
Safety outputs	2 PNP - 500 mA at 24 VDC with short-circuit, overload, polarity reversal protection
Light curtain status indication and weak signal output	PNP - 100 mA at 24 VDC
Muting status indication output	PNP - 100 mA at 24 VDC
Muting lamp output	24 VDC - 0,5 ... 5 W
Muting enable input	0 or 24 VDC (Active Low)
Status display	7-segment display and LEDs for self-diagnosis and light curtain status
External Device Monitoring	External device monitoring feedback input with enabling, selectable
Max. Muting time-out	30 sec. or 90 min. selectable and 30 sec. or infinite selectable for MI TRX models with 4 sensors logic
Override function	Built-in override function with 2 operating modes, selectable: - manual action with hold to run - automatic with pulse command
Max. override time-out (min.)	15
Power supply (VDC)	24 ± 20%
Muting logic	MI TRX - two-way with 2 or 4 sensors and one-way with 2 sensors MI TRXL - two-way with 2 sensors
Muting sensors	External Muting sensors with relay or PNP output (dark-on logic)

CABLES NEEDED

- Main connector TRX active element: M23 19-pole. See [page 48](#) (CJ x, CJM23)
- Option - TRX active element and MJB connection box. See [page 50](#) (CJBR x)

ACCESSORIES

- Safety relay. See [page 46](#)
- MJB connection box. See [page 47](#)
- Support columns. See [page 58](#)
- Laser alignment device. See [page 61](#)
- Vibration dumpers. See [page 60](#)
- Brackets. See [page 60](#)



WITH MUTING FUNCTIONS AND PASSIVE RETRO-REFLECTOR ELEMENT

CONNECTORS

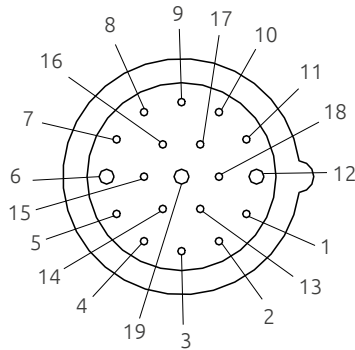
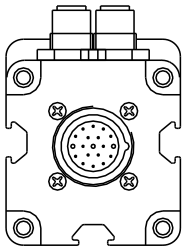

TRX active element
M23 19-pole

- 1 - MUT. LAMP
- 2 - OSSD2 OUT
- 3 - OSSD1 OUT
- 4 - STATUS OUT
- 5 - MUTING STATUS
- 6 - 0 VDC
- 7 - CONF0
- 8 - CONF1
- 9 - CONF2
- 10 - CONF3
- 11 - ENABLE_K IN
- 12 - PE
- 13 - MAN/AUTO
- 14 - RESTART
- 15 - MUTING ENABLE
- 16 - OVERRIDE1
- 17 - OVERRIDE2
- 18 - FEED_K1K2
- 19 - 24 VDC

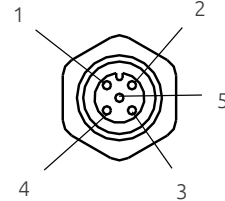

MUTING SENSOR
M12 5-pole

- 1 - 24 VDC
- 2 - SENSOR 1
- 3 - 0 VDC
- 4 - SENSOR 2
- 5 - PE

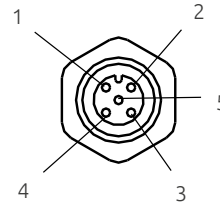

MUTING SENSOR
M12 5-pole

- 1 - 24 VDC
- 2 - SENSOR 3
- 3 - 0 VDC
- 4 - SENSOR 4
- 5 - PE

PART NUMBERS

Access control

Max. range: 6 m



MI TRX - MI TRXL
2, 3, 4 beams

	MI 2B TRX	MI 3B TRX	MI 4B TRX	MI 2B TRXL	MI 3B TRXL	MI 4B TRXL
Ordering codes	1360680	1360682	1360684	1360681	1360683	1360685
Number of beams	2	3	4	2	3	4
Beam spacing (mm)	500	400	300	500	400	300
Protected height (mm)	510	810	910	510	810	910
Overall height (mm)	776	1076	1176	741	1041	1141

JANUS ML TRX

WITH MUTING FUNCTIONS AND PASSIVE RETRO-REFLECTOR ELEMENT

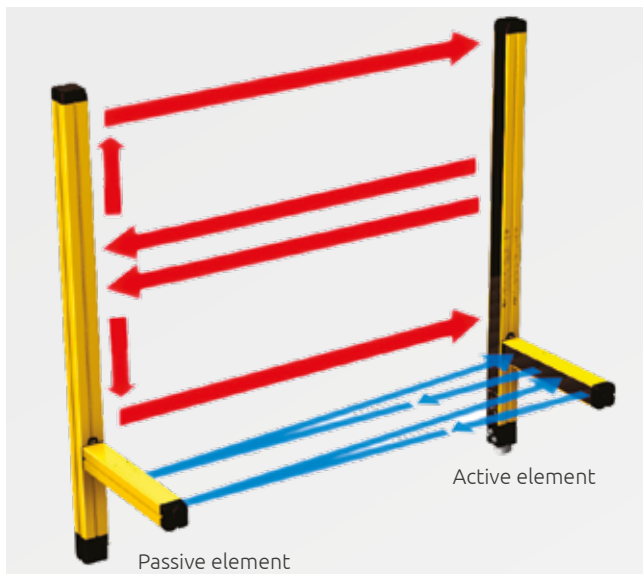

Access control 2, 3, 4 beams	Start/Restart Manual or Automatic	SAFETY LEVEL TYPE 4 SIL 3 - SILCL 3 PL e - Cat. 4
Safety outputs 2	Muting logic One-way	Muting sensors 2 built-in

Built-in Muting function in all the models. Ideal for palletizer applications. Pallet outfeed only. Models with passive retro-reflector elements and reflex Muting sensors built into pre-wired and pre-aligned arms, adjustable in height and angle.

- ML TRX G models (Glass models) with special built-in Muting sensors to optimise correct and consistent detection of glass and transparent materials in general
- ML TRX V models with longer built-in Muting arms available for high-speed conveyors
- ML TRX GV models (Glass models) with special built-in Muting sensors to optimise correct and consistent detection of glass and transparent materials in general and with longer built-in Muting arms available for high-speed conveyors

Input Muting enable and Muting state output.

Configuration is carried out via hardware by means of the main connector.

Unshielded cables up to 100 m long are used. MJB connection box for quick connection of the light curtains and providing the main commands necessary for their operation close to the protected gate.

TECHNICAL FEATURES

Operating range (m)	0 ... 3,5 - ML TRX, ML TRX V 0 ... 2 - ML TRX G, ML TRX GV
Response time (ms)	≤ 10,5
Safety outputs	2 PNP - 500 mA at 24 VDC with short-circuit, overload, polarity reversal protection
Light curtain status indication and weak signal output	PNP - 100 mA at 24 VDC
Muting status indication output	PNP - 100 mA at 24 VDC
Muting lamp output	24 VDC - 0,5 ... 5 W
Muting enable input	0 or 24 VDC (Active Low)
Status display	7-segment display and LEDs for self-diagnosis and light curtain status
External Device Monitoring	External device monitoring feedback input with enabling, selectable
Max. Muting time-out	30 sec. or 90 min. selectable
Override function	Built-in override function with 2 operating modes, selectable: - manual action with hold to run - automatic with pulse command
Max. override time-out (min.)	15
Power supply (VDC)	24 ± 20%
Muting logic	One-way with 2 sensors
Muting sensors	Reflex optoelectronics with 2 parallel beams built-in - pre-aligned - pre-wired, with adjustable height and angle

CABLES NEEDED

- Main connector TRX active element: M23 19-pole
See [page 48](#) (CJ x, CJM23)
- Option - TRX active element and MJB connection box.
See [page 50](#) (CJBR x)

ACCESSORIES

- Safety relay. See [page 46](#)
- MJB connection box. See [page 47](#)
- Support columns. See [page 58](#)
- Laser alignment device. See [page 61](#)
- Vibration dumpers. See [page 60](#)
- Brackets. See [page 60](#)



WITH MUTING FUNCTIONS AND PASSIVE RETRO-REFLECTOR ELEMENT

CONNECTORS

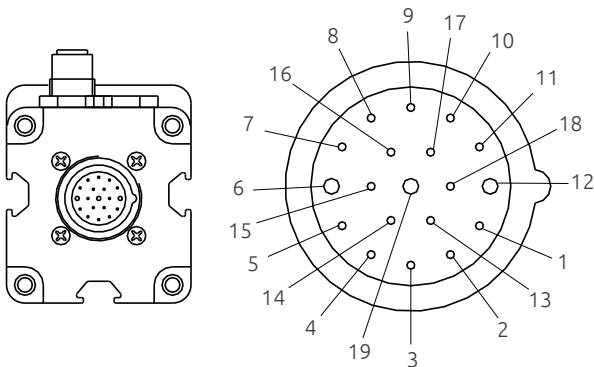

TRX active element
M23 19-pole

- 1 - MUT. LAMP
- 2 - OSSD2 OUT
- 3 - OSSD1 OUT
- 4 - STATUS OUT
- 5 - MUTING STATUS
- 6 - 0 VDC
- 7 - CONF0
- 8 - CONF1
- 9 - CONF2
- 10 - CONF3
- 11 - ENABLE_K IN
- 12 - PE
- 13 - MAN/AUTO
- 14 - RESTART
- 15 - MUTING ENABLE
- 16 - OVERRIDE1
- 17 - OVERRIDE2
- 18 - FEED_K1K2
- 19 - 24 VDC

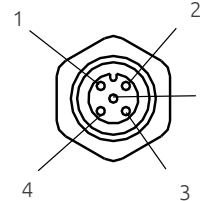

MUTING SENSOR
M12 5-pole

- 1 - 24 VDC
- 2 - SENSOR 1
- 3 - 0 VDC
- 4 - SENSOR 2
- 5 - PE

PART NUMBERS

Access control

Max. range: 3,5 m



ML TRX - ML TRX G
2, 3 beams

ML 2B TRX

ML 2B TRX G

ML 3B TRX

ML 3B TRX G

Ordering codes

1360040

1360042

1360041

1360043



ML TRX V - ML 2B TRX GV
2, 3 beams

ML 2B TRX V

ML 2B TRX GV

ML 3B TRX V

ML 3B TRX GV

Ordering codes

1360044

1360046

1360045

1360047

Number of beams

2

3

Beam spacing (mm)

500

400

Protected height (mm)

510

810

Overall height (mm)

776

1076

Muting sensors

2 parallel beams

2 parallel beams
(transparent material)

2 parallel beams

2 parallel beams
(transparent material)



Example of application of Janus ML TRX light curtain for protection of palletizer outfeed zone.

JANUS MT TRX

WITH MUTING FUNCTIONS AND PASSIVE RETRO-REFLECTOR ELEMENT

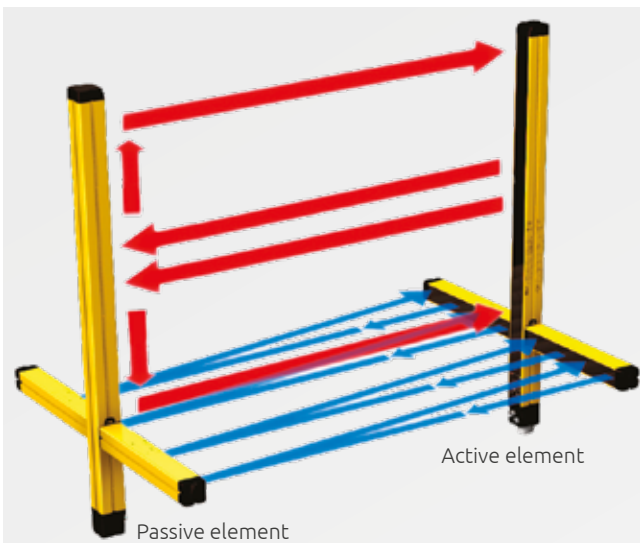

Access control 2, 3, 4 beams	Start/Restart Manual or Automatic	SAFETY LEVEL TYPE 4 SIL 3 - SILCL 3 PL e - Cat. 4
Safety outputs 2	Muting logic Two-way	Muting sensors 4 built-in

Built-in Muting function in all the models. Ideal for palletizer applications. Pallet infeed and outfeed. Models with passive retro-reflector elements and reflex Muting sensors built into pre-wired and pre-aligned arms, adjustable in height and angle.

- MT TRX G models (Glass models) with special built-in Muting sensors to optimise correct and consistent detection of glass and transparent materials in general
- MT TRX V models with longer built-in Muting arms available for high-speed conveyors
- MT TRX GV models (Glass models) with special built-in Muting sensors to optimise correct and consistent detection of glass and transparent materials in general and with longer built-in Muting arms available for high-speed conveyors

Input Muting enable and Muting state output.

Configuration is carried out via hardware by means of the main connector.

Unshielded cables up to 100 m long are used. MJB connection box for quick connection of the light curtains and providing the main commands necessary for their operation close to the protected gate.

TECHNICAL FEATURES

Operating range (m)	0 ... 3,5 - MT TRX, MT TRX V 0 ... 2 - MT TRX G, MT TRX GV
Response time (ms)	≤ 10,5
Safety outputs	2 PNP - 500 mA at 24 VDC with short-circuit, overload, polarity reversal protection
Light curtain status indication and weak signal output	PNP - 100 mA at 24 VDC
Muting status indication output	PNP - 100 mA at 24 VDC
Muting lamp output	24 VDC - 0,5 ... 5 W
Muting enable input	0 or 24 VDC (Active Low)
Status display	7-segment display and LEDs for self-diagnosis and light curtain status
External Device Monitoring	External device monitoring feedback input with enabling, selectable
Max. Muting time-out	30 sec. or 90 min. selectable and 30 sec. or infinite selectable
Override function	Built-in override function with 2 operating modes, selectable: - manual action with hold to run - automatic with pulse command
Max. override time-out (min.)	15
Power supply (VDC)	24 ± 20%
Muting logic	Two-way sequential with 4 sensors
Muting sensors	Reflex optoelectronics with 4 parallel beams built-in - pre-aligned - pre-wired, with adjustable height and angle

CABLES NEEDED

- Main connector TRX active element: M23 19-pole. See [page 48](#) (CJ x, CJM23)
- Option - TRX active element and MJB connection box. See [page 50](#) (CJBR x)

ACCESSORIES

- Safety relay. See [page 46](#)
- MJB connection box. See [page 47](#)
- Support columns. See [page 58](#)
- Laser alignment device. See [page 61](#)
- Vibration dumpers. See [page 60](#)
- Brackets. See [page 60](#)



WITH MUTING FUNCTIONS AND PASSIVE RETRO-REFLECTOR ELEMENT

CONNECTORS

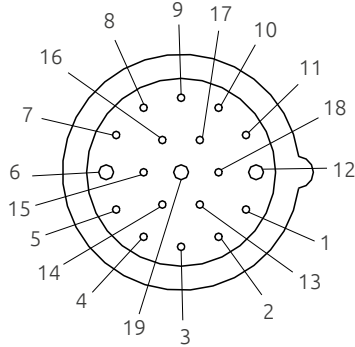
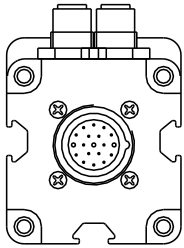

TRX active element
M23 19-pole

- 1 - MUT. LAMP
- 2 - OSSD2 OUT
- 3 - OSSD1 OUT
- 4 - STATUS OUT
- 5 - MUTING STATUS
- 6 - 0 VDC
- 7 - CONF0
- 8 - CONF1
- 9 - CONF2
- 10 - CONF3
- 11 - ENABLE_K IN
- 12 - PE
- 13 - MAN/AUTO
- 14 - RESTART
- 15 - MUTING ENABLE
- 16 - OVERRIDE1
- 17 - OVERRIDE2
- 18 - FEED_K1K2
- 19 - 24 VDC

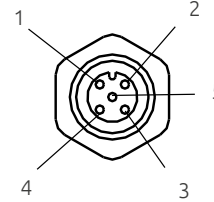

MUTING SENSOR
M12 5-pole

- 1 - 24 VDC
- 2 - SENSOR 1
- 3 - 0 VDC
- 4 - SENSOR 2
- 5 - PE

PART NUMBERS

Access control

Max. range: 3,5 m



MT TRX - MT TRX G
2, 3 beams

	MT 2B TRX	MT 2B TRX G	MT 3B TRX	MT 3B TRX G
Ordering codes	1360050	1360052	1360051	1360053



MT TRX V - MT TRX GV
2, 3 beams

	MT 2B TRX V	MT 2B TRX GV	MT 3B TRX V	MT 3B TRX GV
Ordering codes	1360054	1360056	1360055	1360057
Number of beams	2		3	
Beam spacing (mm)	500		400	
Protected height (mm)	510		810	
Overall height (mm)	776		1076	
Muting sensors	4 parallel beams	4 parallel beams (transparent material)	4 parallel beams	4 parallel beams (transparent material)

JANUS MM TRX

WITH MUTING FUNCTIONS AND PASSIVE RETRO-REFLECTOR ELEMENT



Access control 2, 3, 4 beams	Start/Restart Manual or Automatic	SAFETY LEVEL TYPE 4 SIL 3 - SILCL 3 PL e - Cat. 4
Safety outputs 2	Muting logic One-way Two-way	
		Muting sensors 2 or 4 built-in

Built-in Muting function in all the models. Ideal for palletizer applications, pallet infeed and outfeed.

Modular system which permits to add pre-wired Muting arms so that the light grid can be used either as one-way (ML TRX) or as two-way (MT TRX) system with a few simple steps.

MM TRX can also be used with external Muting sensors, with 2 or 4 sensors logic.

Input Muting enable and Muting state output.

Configuration is carried out via hardware by means of the main connector.

Unshielded cables up to 100 m long are used.

MJB connection box for quick connection of the light curtains and providing the main commands necessary for their operation close to the protected gate.

TECHNICAL FEATURES

Max. range (m)	6 (3,5 when fitted with SL TRX and ST TRX)
Response time (ms)	≤ 10,5
Safety outputs	2 PNP - 500 mA at 24 VDC with short-circuit, overload, polarity reversal protection
Light curtain status indication and weak signal output	PNP - 100 mA at 24 VDC
Muting status indication output	PNP - 100 mA at 24 VDC
Muting lamp output	24 VDC - 0,5 ... 5 W
Muting enable input	0 or 24 VDC (Active Low)
Status display	7-segment display and LEDs for self-diagnosis and light curtain status
External Device Monitoring	External device monitoring feedback input with enabling, selectable
Max. Muting time-out	30 sec. or 90 min. selectable and 30 sec. or infinite selectable
Override function	Built-in override function with 2 operating modes, selectable: - manual action with hold to run - automatic with pulse command
Max. override time-out (min.)	15
Power supply (VDC)	24 ± 20%
Muting logic	Two-way with 2 or 4 external sensors and one-way with 2 external sensors
Muting sensors	External Muting sensors with relay or PNP output (dark-on logic) Reflex optoelectronics with 2 parallel beams Built-in - pre-aligned - pre-wired, with adjustable height and angle Reflex optoelectronics with 4 parallel beams Built-in - pre-aligned - pre-wired, with adjustable height and angle

CABLES NEEDED

- Main connector TRX active element: M23 19-pole. See [page 48](#) (CJ x, CIM23)
- Muting sensors: M12 5-pole. See [page 50](#) (CJ95, CIM9)
- Option - TRX active element and MJB connection box. See [page 50](#) (CJBR x)



WITH MUTING FUNCTIONS AND PASSIVE RETRO-REFLECTOR ELEMENT

ACCESSORIES

- Safety relay. See [page 46](#)
- Janus SL TRX and ST TRX - Accessory Muting sensor elements. See [page 54](#)
- MJB connection box. See [page 47](#)
- Support columns. See [page 58](#)
- Laser alignment device. See [page 61](#)
- Vibration dumpers. See [page 60](#)
- Brackets. See [page 60](#)

CONNECTORS

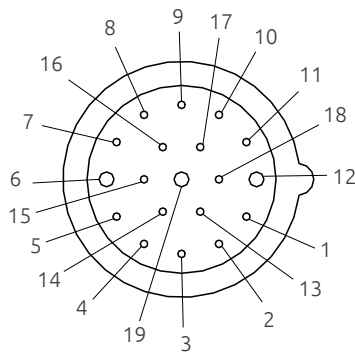
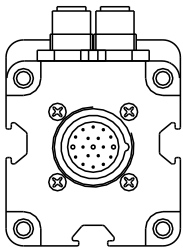

TRX active element
M23 19-pole

- 1 - MUT. LAMP
- 2 - OSSD2 OUT
- 3 - OSSD1 OUT
- 4 - STATUS OUT
- 5 - MUTING STATUS
- 6 - 0 VDC
- 7 - CONF0
- 8 - CONF1
- 9 - CONF2
- 10 - CONF3
- 11 - ENABLE_K IN
- 12 - PE
- 13 - MAN/AUTO
- 14 - RESTART
- 15 - MUTING ENABLE
- 16 - OVERRIDE1
- 17 - OVERRIDE2
- 18 - FEED_K1K2
- 19 - 24 VDC

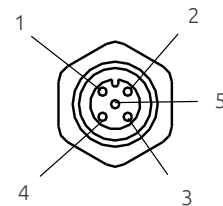

MUTING SENSOR
M12 5-pole

- 1 - SENSOR 1
- 2 - 0 VDC
- 3 - SENSOR 2
- 4 - 24 VDC
- 5 - PE

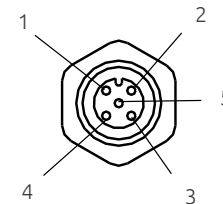

MUTING SENSOR
M12 5-pole

- 1 - SENSOR 3
- 2 - 0 VDC
- 3 - SENSOR 4
- 4 - 24 VDC
- 5 - PE

PART NUMBERS

Access control Max. range: 6 m



MM TRX

2,3 beams

MM 2B TRX

MM 3B TRX

MM 4B TRX

Ordering codes	1360690	1360691	1360692
Number of beams	2	3	4
Beam spacing (mm)	500	400	300
Protected height (mm)	510	810	910
Overall height (mm)	776	1076	1176



Access control 2, 3, 4 beams	Start/Restart Manual or Automatic	SAFETY LEVEL TYPE 4 SIL 3 - SILCL 3 PL e - Cat. 4
Safety outputs 2		

Built-in Start/Restart interlock, selectable.

All configuration via hardware by means of main connector.

Use of unshielded cables up to 100 m long.

MJB connection box for quick connection of the light curtains and availability of the Restart command in the area of the protected gate.

TECHNICAL FEATURES

Max. range (m)	Selectable 6 or 16
Response time (ms)	7 ... 28,5
Safety outputs	2 PNP - 500 mA at 24 VDC with short-circuit, overload, polarity reversal protection
Light curtain status indication and weak signal output	PNP - 100 mA at 24 VDC
Status display	Seven-segment display and LEDs for light curtain's status and diagnostic
External Device Monitoring	External device monitoring feedback input with enabling, selectable
Power supply (VDC)	24 ± 20%

CABLES NEEDED

- Emitter: M12 5-pole. See [page 48 - 49](#) (CDx CDx SB, CD9x, CDM9, CDM99)
- Receiver: M23 19-pole. See [page 48](#) (CJx, CJM23)

ACCESSORIES

- Safety relay. See [page 46](#)
- MJB connection box. See [page 47](#)
- Support columns. See [page 58](#)
- Laser alignment device. See [page 61](#)
- Vibration dumpers. See [page 60](#)
- Brackets. See [page 60](#)



WITH BUILT-IN CONTROL FUNCTIONS

CONNECTORS

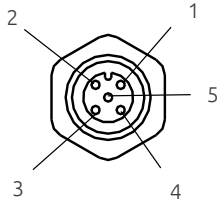

EMITTER
M12 5-pole
1 - 24 VDC
2 - TEST
3 - 0 VDC
4 - NC
5 - PE

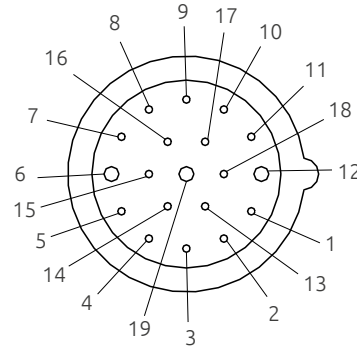

RECEIVER
M23 19-pole
1 - MUT. LAMP
2 - OSSD2 OUT
3 - OSSD1 OUT
4 - STATUS OUT
5 - NC
6 - 0 VDC
7 - CONF0
8 - CONF1
9 - CONF2
10 - CONF3
11 - ENABLE_K IN
12 - PE
13 - MAN/AUTO
14 - RESTART
15 - NC
16 - OVERRIDE1
17 - OVERRIDE2
18 - FEED_K1K2
19 - 24 VDC

PART NUMBERS

Access control Max. range: selectable 6 or 16 m



J 2, 3, 4 beams

	J 2B	J 3B	J 4B
Ordering codes	1360640	1360641	1360642
Number of beams	2	3	4
Beam spacing (mm)	500	400	300
Protected height (mm)	510	810	910
Overall height (mm)	741	1041	1141

JANUS J LR

WITH BUILT-IN CONTROL FUNCTIONS



Resolution (mm)	Start/Restart	SAFETY LEVEL TYPE 4 SIL 3 - SILCL 3 PL e - Cat. 4
40	Manual or Automatic	
Access control	Safety outputs	
2, 3, 4 beams	2	

Built-in Start/Restart interlock, selectable.

All configuration via hardware by means of main connector.

LR models with max. range up to 60 m.

Janus J LRH M12 and J LRH M12 ILP models with Max. range up to 80 meters. Models ILP with integrated laser pointer.

Use of unshielded cables up to 100 m long.

MJB connection box for quick connection of the light curtains and availability of the Restart command in the area of the protected gate.

Protected heights: 510 ... 1210 (mm).



TECHNICAL FEATURES

Max. range (m)	Selectable 30 or 60 for LR models Selectable 40 or 80 for LRH models
Response time (ms)	7 ... 28,5
Safety outputs	2 PNP - 500 mA at 24 VDC with short-circuit, overload, polarity reversal protection
Light curtain status indication and weak signal output	PNP - 100 mA at 24 VDC
Status display	Seven-segment display and LEDs for light curtain's status and diagnostic
External Device Monitoring	External device monitoring feedback input with enabling, selectable
Power supply (VDC)	24 ± 20%
Laser pointer Max. power (mW)	<1 (class 1M according to the EN 60825-1) not dangerous to the eyes and skin. One laser pointer per beams.

CABLES NEEDED

- Emitter: M12 5-pole. See [page 48](#) (CDx CDx SB, CD9x, CDM9, CDM99)
- Receiver: M23 19-pole. See [page 48](#) (CJx, CJM23)
- Receiver for J LR M12 models: M12 8-pole. See [page 52](#) (C8Dx, C8Dx SB, C8D9x, C8DM11, C8DM911)

ACCESSORIES

- Safety relay. See [page 46](#)
- MJB connection box. See [page 47](#)
- Support columns. See [page 58](#)
- Laser alignment device. See [page 61](#)
- Vibration dumpers. See [page 60](#)
- Brackets. See [page 60](#)

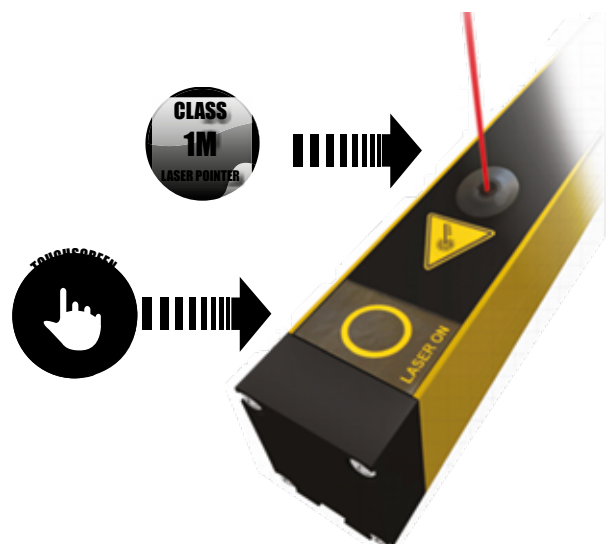

CONNECTORS

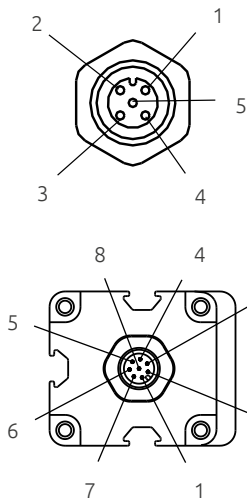

EMITTER
M12 5-pole
1 - 24 VDC
2 - TEST
3 - 0 VDC
4 - NC
5 - PE

RECEIVER (for J LR M12)
M12 8-pole
1 - OSSD 1
2 - 24 VDC
3 - OSSD 2
4 - EXT_K1_K2
5 - EXT_SEL_A
6 - EXT_SEL_B
7 - 0 VDC
8 - PE

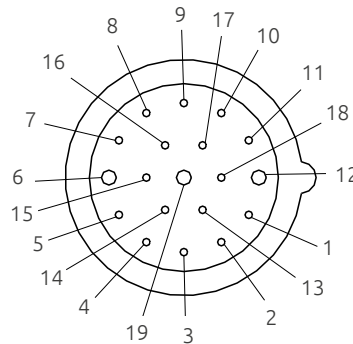

RECEIVER
M23 19-pole
1 - MUT. LAMP
2 - OSSD2 OUT
3 - OSSD1 OUT
4 - STATUS OUT
5 - NC
6 - 0 VDC
7 - CONF0
8 - CONF1
9 - CONF2
10 - CONF3
11 - ENABLE_K IN
12 - PE
13 - MAN/AUTO
14 - RESTART
15 - NC
16 - OVERRIDE1
17 - OVERRIDE2
18 - FEED_K1K2
19 - 24 VDC

PART NUMBERS

Hand detection Max. range: selectable 30 or 60 m



J Long Range - Resolution 40 mm	J 604 LR	J 904 LR	J 1204 LR
Ordering codes	1360363	1360365	1360367
Protected height (mm)	610	910	1210
Number of beams	30	45	60
Overall height (mm)	741	1041	1341
Max. range (m)	selectable 30 or 60		

Access control Max. range: selectable 30 or 60 m



J Long Range - 2, 3, 4 beams	J 2B LR	J 3B LR	J 4B LR
Ordering codes	1360630	1360631	1360632
J Long Range M12 - 2, 3, 4 beams	J 2B LR M12	J 3B LR M12	J 4B LR M12
Ordering codes	1360634	1360635	1360636
Number of beams	2	3	4
Beam spacing (mm)	500	400	300
Protected height (mm)	510	810	910
Overall height (mm)	741 - 736 (J ... M12 models)	1041 - 1036 (J ... M12 models)	1141 - 1136 (J ... M12 models)

Access control Max. range: selectable 40 or 80 m



J LRH M12 - 2, 3, 4 beams	J 2B LRH M12	J 3B LRH M12	J 4B LRH M12
Ordering codes	1360637	1360638	1360639
J LRH M12 ILP - 2, 3, 4 beams	J 2B LRH M12 ILP	J 3B LRH M12 ILP	J 4B LRH M12 ILP
Ordering codes	1360646	1360647	1360648
Number of beams	2	3	4
Beam spacing (mm)	500	400	300
Protected height (mm)	510	810	910
Overall height (mm)	736	1036	1136

JANUS J TRX

WITH BUILT-IN CONTROL FUNCTIONS AND PASSIVE RETRO-REFLECTOR ELEMENT

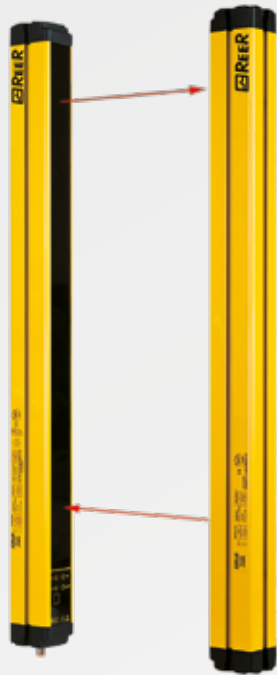

Access control	Start/Restart	SAFETY LEVEL TYPE 4 SIL 3 - SILCL 3 PL e - Cat. 4
2, 3, 4 beams	Manual or Automatic	
Safety outputs		
2		

Janus J TRX and J TRXL are safety light grids with 2, 3, 4 beams consisting of an active element (emitter/receiver) and a retro-reflector passive element which does not require electrical connections.

Simplest and quickest installation solutions for detection of a person in access control in hazardous areas, and the ideal solutions for all applications in which it is difficult or costly to cable electrical lines.

Built-in Start/Restart interlock, selectable.

All configuration via hardware by means of main connector. No need of configuration via software.

Use of unshielded cables up to 100 m long.

MJB connection box for quick connection of the light curtains and availability of the Restart command in the area of the protected gate (only for model J TRX L).

TECHNICAL FEATURES

Max. range (m)	6
Response time (ms)	≤ 7
Safety outputs	2 PNP auto-controlled - 500 mA at 24 VDC with short-circuit, overload, polarity reversal protection
Status display	Seven-segment display and LEDs for light curtain's status and diagnostic
External Device Monitoring	External device monitoring feedback input with enabling selectable
Power supply (VDC)	24 ± 20%

CABLES NEEDED

- J TRXL models: M23 19-pole. See [page 48](#) (CJ x, CJM23)
- J TRX model: M12 8-pole. See [page 52](#) (C8D x, C8D x SB, C8D9 x, C8DM 11, C8DM 911)

ACCESSORIES

- Safety relay. See [page 46](#)
- MJB connection box. See [page 47](#)
- Support columns. See [page 58](#)
- Laser alignment device. See [page 61](#)
- Vibration dumpers. See [page 60](#)
- Brackets. See [page 60](#)



CONNECTORS

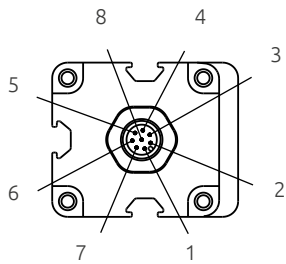

J TRX active element
M12 8-pole

- 1 - OSSD 1
- 2 - 24 VDC
- 3 - OSSD 2
- 4 - EXT_K1_K2
- 5 - EXT_SEL_A
- 6 - EXT_SEL_B
- 7 - 0 VDC
- 8 - PE

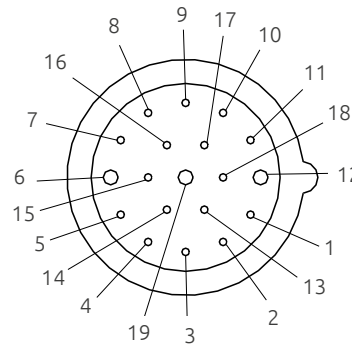

J TRX L active element
M23 19-pole

- 1 - MUT. LAMP
- 2 - OSSD2 OUT
- 3 - OSSD1 OUT
- 4 - STATUS OUT
- 5 - NC
- 6 - 0 VDC
- 7 - CONF0
- 8 - CONF1
- 9 - CONF2
- 10 - CONF3
- 11 - ENABLE_K IN
- 12 - PE
- 13 - MAN/AUTO
- 14 - RESTART
- 15 - NC
- 16 - OVERRIDE1
- 17 - OVERRIDE2
- 18 - FEED_K1K2
- 19 - 24 VDC

PART NUMBERS

Access control

Max. range: 6 m



J TRX / J TRXL - 2, 3, 4 beams	J 2B TRX	J 3B TRX	J 4B TRX	J 2B TRXL	J 3B TRXL	J 4B TRXL
Ordering codes	1360650	1360656	1360655	1360651	1360652	1360653
Number of beams	2	3	4	2	3	4
Beam spacing (mm)	500	400	300	500	400	300
Protected height (mm)	510	810	910	510	810	910
Overall height (mm)	741	1041	1141	741	1041	1141
Connector	M12 8-pole	M12 8-pole	M12 8-pole	M23 19-pole	M23 19-pole	M23 19-pole

MECHANICAL DATA

JANUS MI

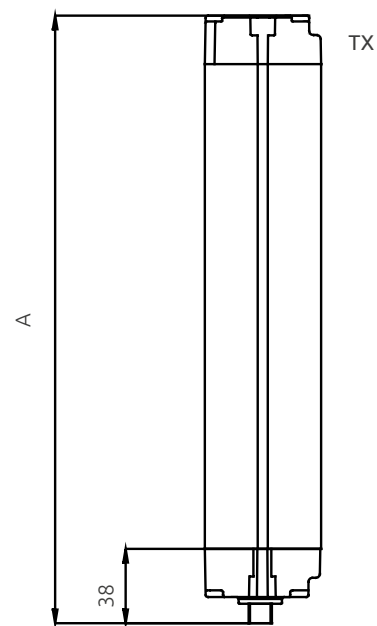
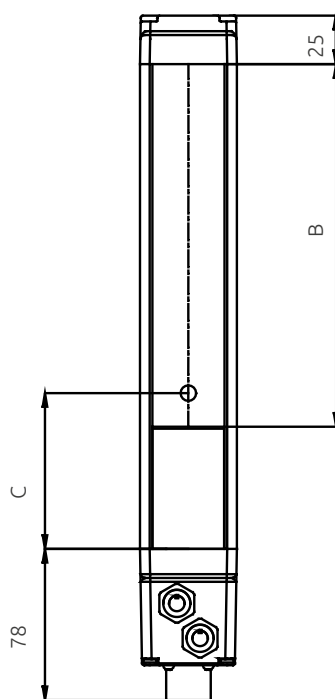
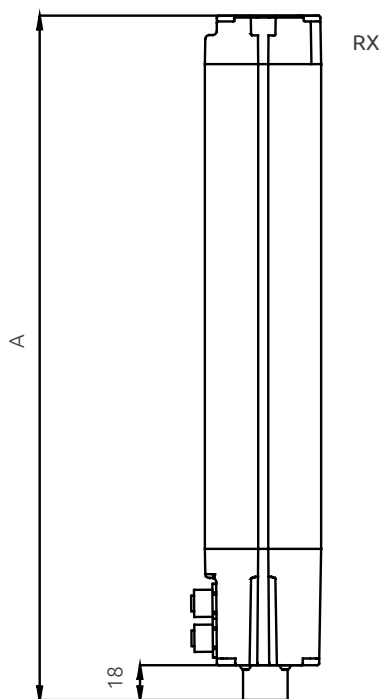
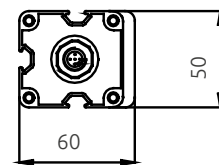
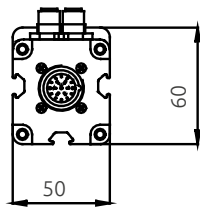

DIMENSIONS	16 m range											Long Range					
	300	450	600	750	900	1050	1200	1350	1500	1650	1800	2B	3B	4B	2B	3B	4B
A TX (mm)	436	586	736	886	1036	1186	1336	1486	1636	1786	1936	736	1036	1136	736	1036	1136
A RX (mm)	476	626	776	926	1076	1226	1376	1526	1676	1826	1976	776	1076	1176	776	1076	1176
B Protected height (mm)	310	460	610	760	910	1060	1210	1360	1510	1660	1810	510*	810*	910*	510*	810*	910*
C 1 st beam position (mm)	72											120			76		

NOTE: * for these models the protected height is only indicative and is calculated based on the beams spacing.

Mounting:

- Models with $A < 1050$ - Complete set of 4 LL type brackets included in the package
- Models with $A \geq 1050$ - Complete set of 6 LL type brackets included in the package

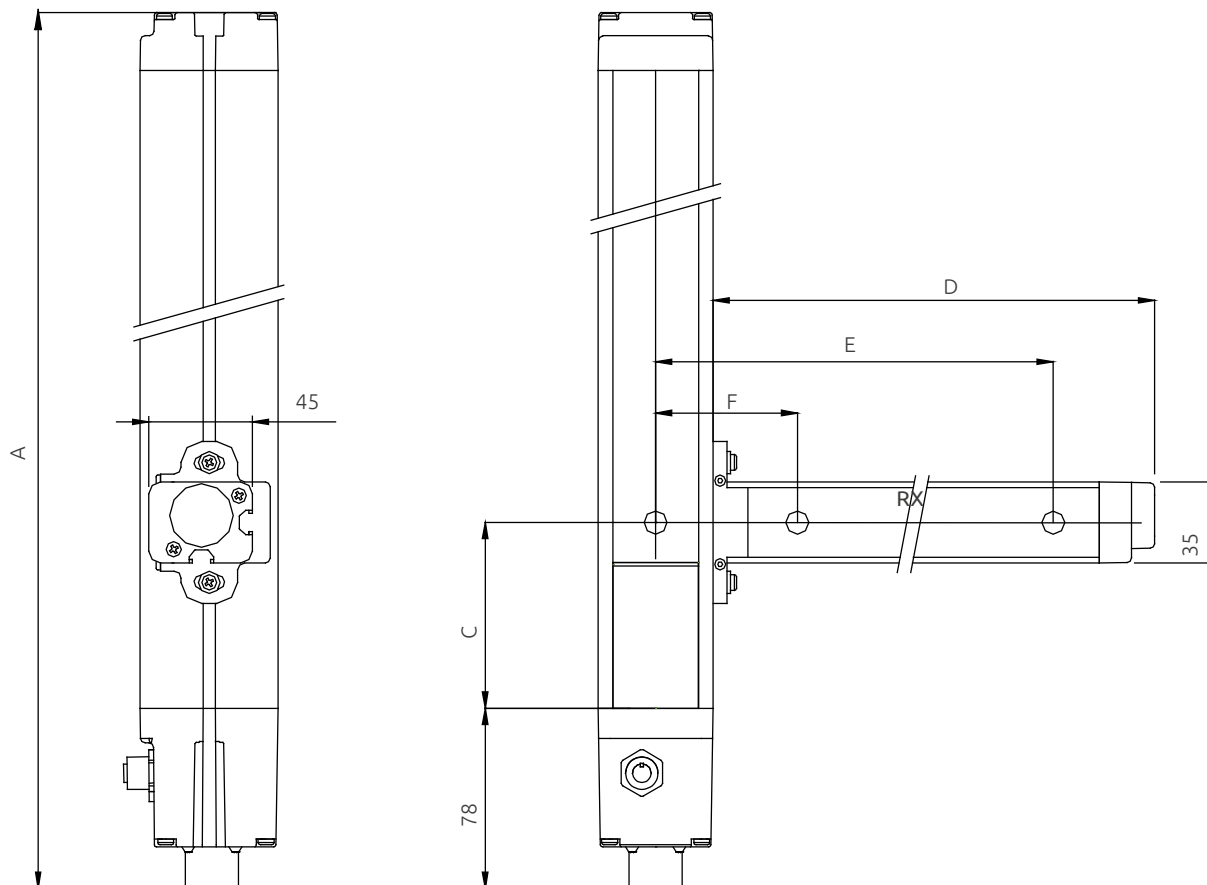

DIMENSIONS	2B	3B
A TX-RX (mm)	776	1076
C 1 st beam position (mm)	120	
D (mm)	330	
E (mm)	300	
F (mm)	50	

Mounting:

- 2B - Complete set of 4 type LL brackets included in the package
- 3B - Complete set of 6 type LL brackets included in the package

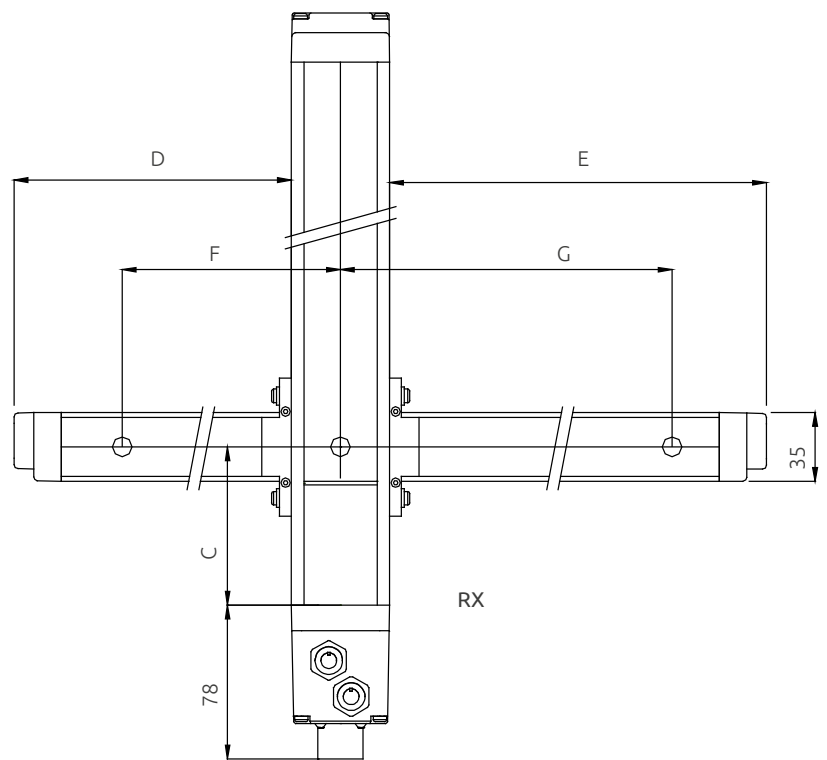
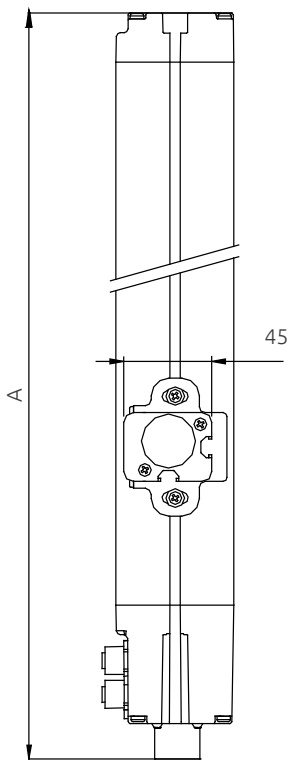

DIMENSIONS	2B	3B
A TX-RX (mm)	776	1076
C 1 st beam position (mm)	120	
D (mm)	230	
E (mm)	330	
F (mm)	200	
G (mm)	300	

Mounting:

- 2B - Complete set of 4 type LL brackets included in the package
- 3B - Complete set of 6 type LL brackets included in the package

JANUS ML S2 - MT S4

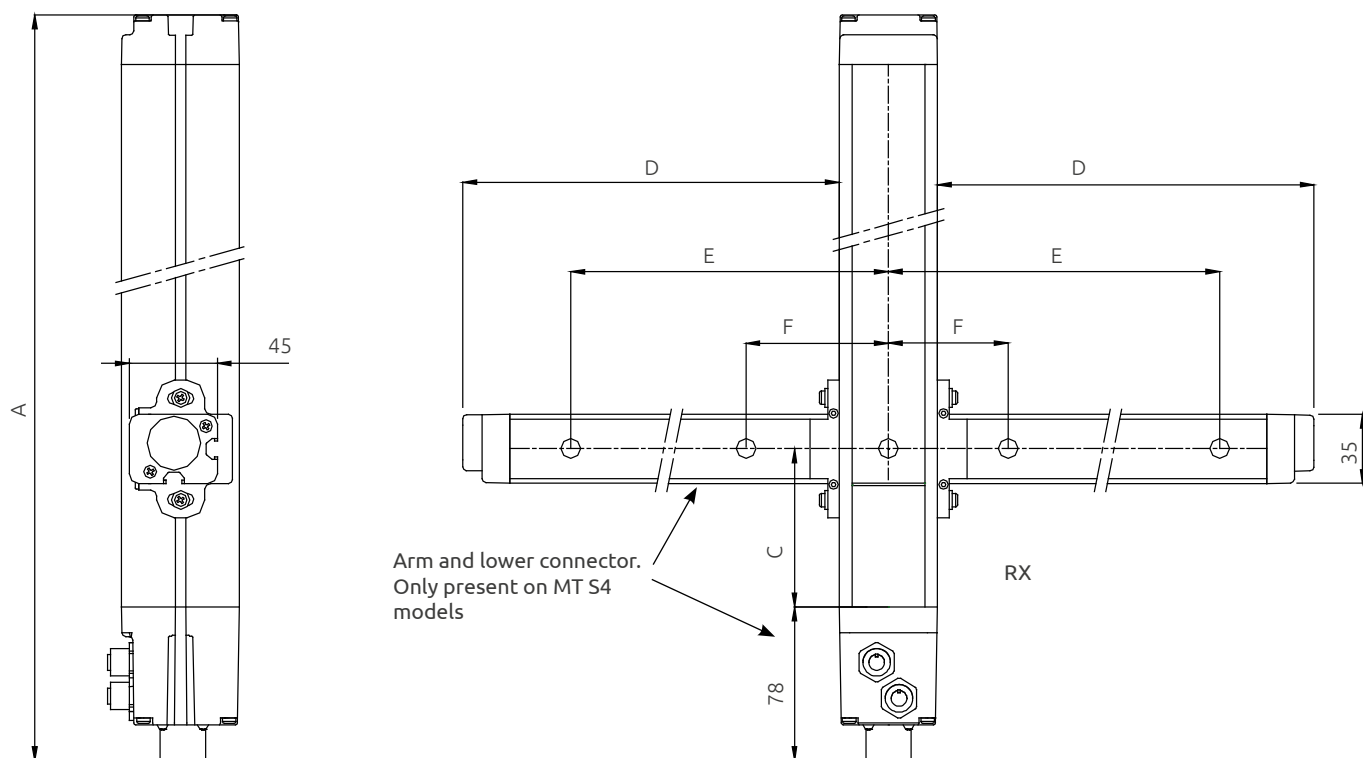

DIMENSIONS	2B	3B
C 1 st beam position (mm)	120	
D (mm)	370	
E (mm)	334	
F (mm)	84	

Mounting:

- 2B - Complete set of 4 type LL brackets included in the package
- 3B - Complete set of 6 type LL brackets included in the package

JANUS MI TRX - MI TRXL - MM TRX

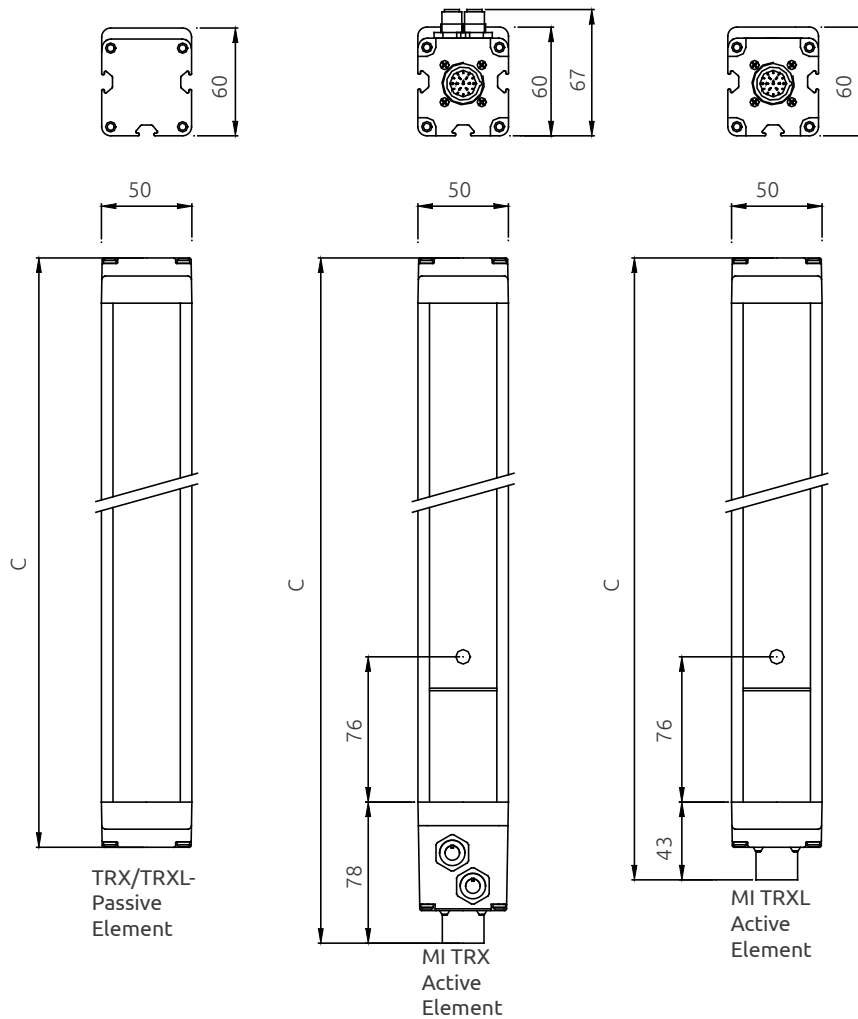

DIMENSIONS	2B	3B	4B
A (mm)	741	1041	1141
B (mm)	776	1076	1176
C (mm)	723	1023	1123

Mounting:

2B, 3B, 4B - Complete set of 2 type LH brackets included in the package

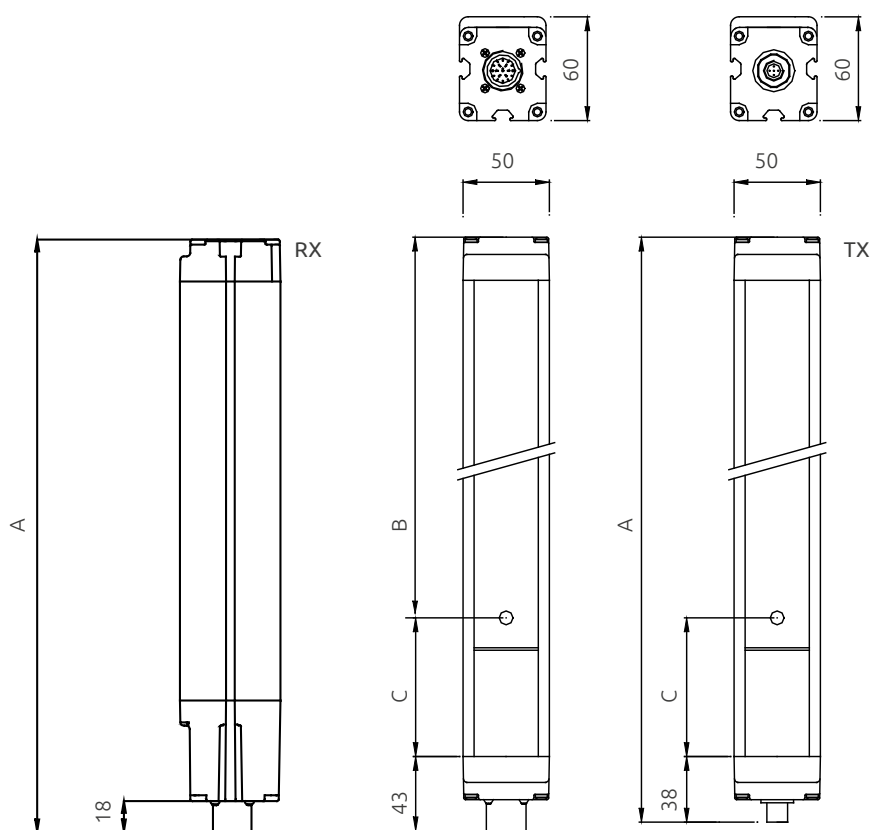

DIMENSIONS	16 m range			Long Range					
	2B	3B	4B	600	900	1200	2B	3B	4B
A TX-RX (mm)	736	1036	1136	736	1036	1336	736	1036	1136
B Protected height (mm)	510*	810*	910*	610	910	1210	510*	810*	910*
C 1 st beam position (mm)	120			76					

NOTE: * for these models the protected height is only indicative and is calculated based on the beams spacing.

Mounting:

- Models with $A < 1050$ - Complete set of 4 LL type brackets included in the package
- Models with $A \geq 1050$ - Complete set of 6 LL type brackets included in the package

JANUS J TRX - J TRXL

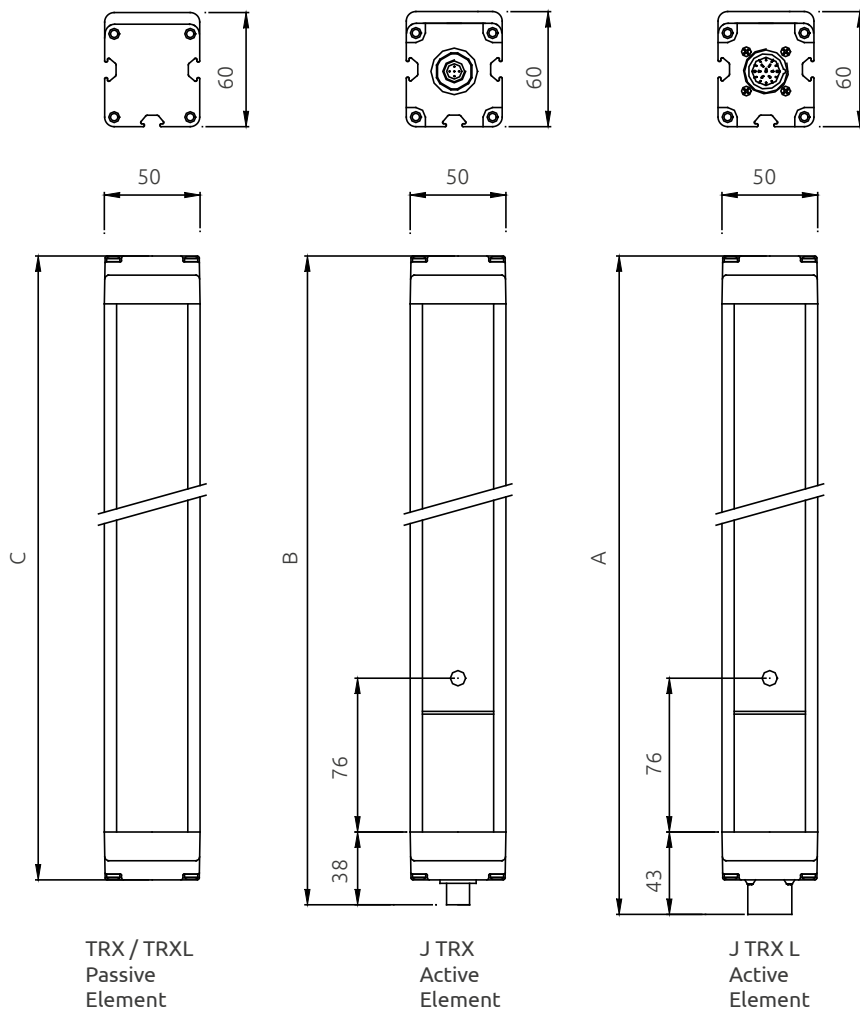

DIMENSIONS	2B	3B	4B
A (mm)	741	1041	1141
B (mm)	736	1036	1136
C (mm)	723	1023	1123

Mounting:

2B, 3B, 4B - Complete set of 2 type LH brackets included in the package

JANUS ML TRX - ML TRX G

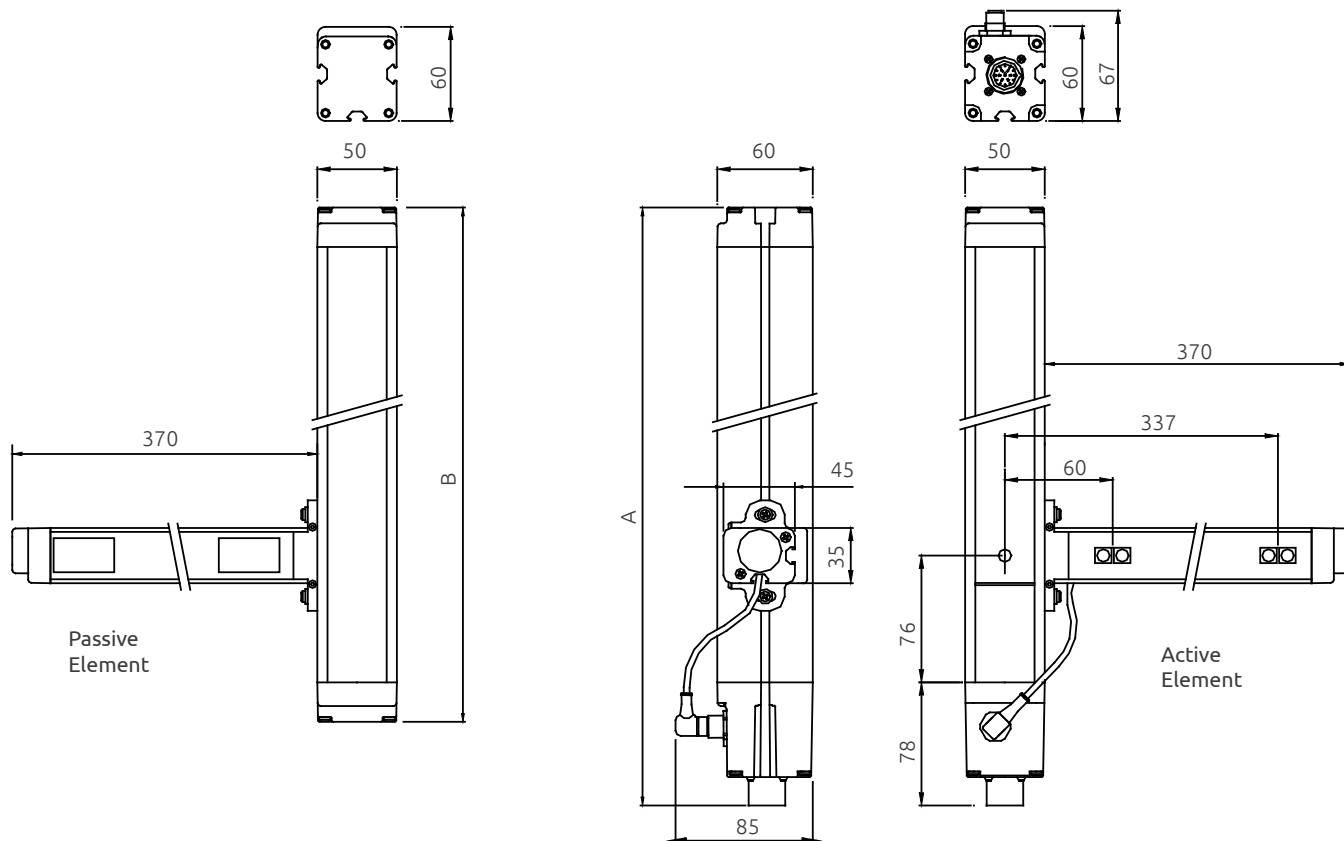

DIMENSIONS	2B	3B
A (mm)	776	1076
B (mm)	723	1023

Mounting:

- 2B - Complete set of 4 type LL brackets included in the package
- 3B - Complete set of 6 type LL brackets included in the package

JANUS ML TRX V - ML TRX GV

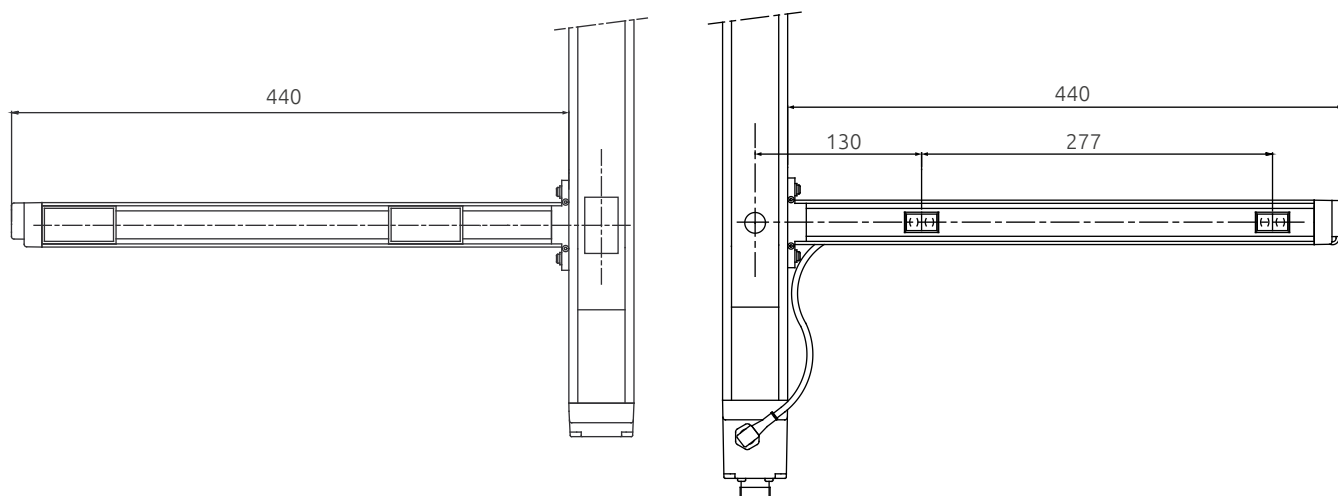

Mounting:

- 2B - Complete set of 4 type LL brackets included in the package
- 3B - Complete set of 6 type LL brackets included in the package

JANUS MT TRX - MT TRX G

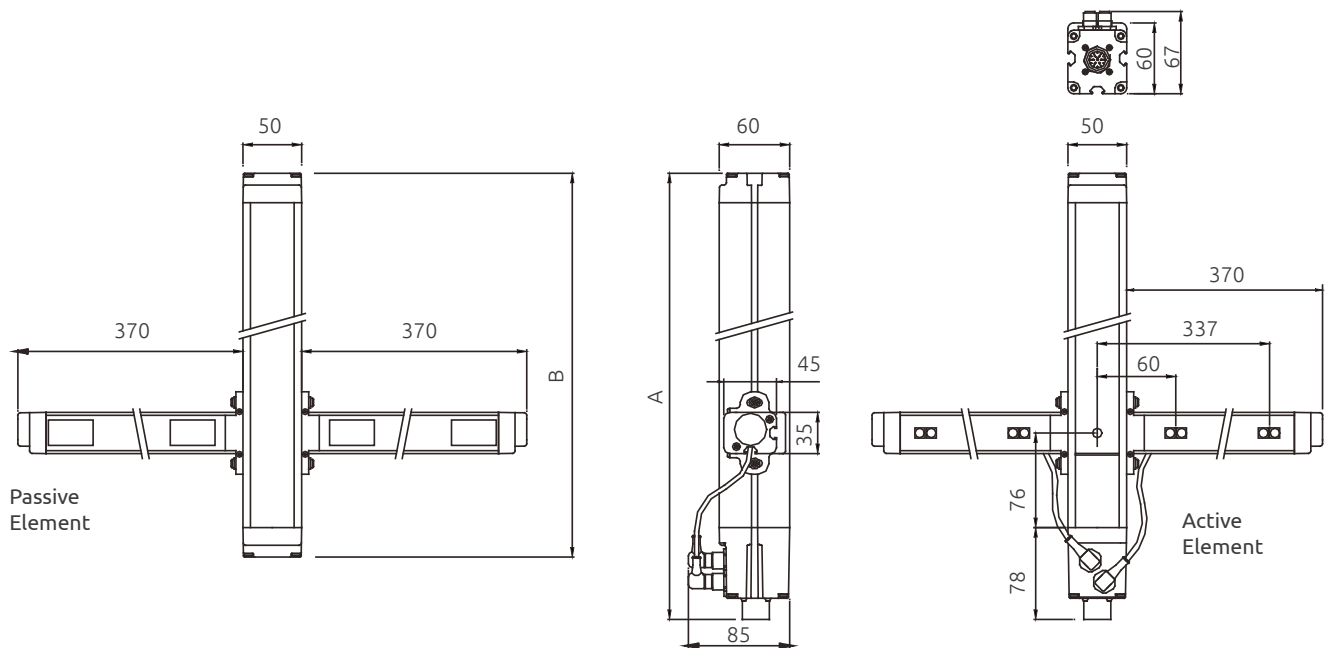

DIMENSIONS	2B	3B
A (mm)	776	1076
B (mm)	723	1023

Mounting:

- 2B - Complete set of 4 type LL brackets included in the package
- 3B - Complete set of 6 type LL brackets included in the package

JANUS MT TRX V - MT TRX GV

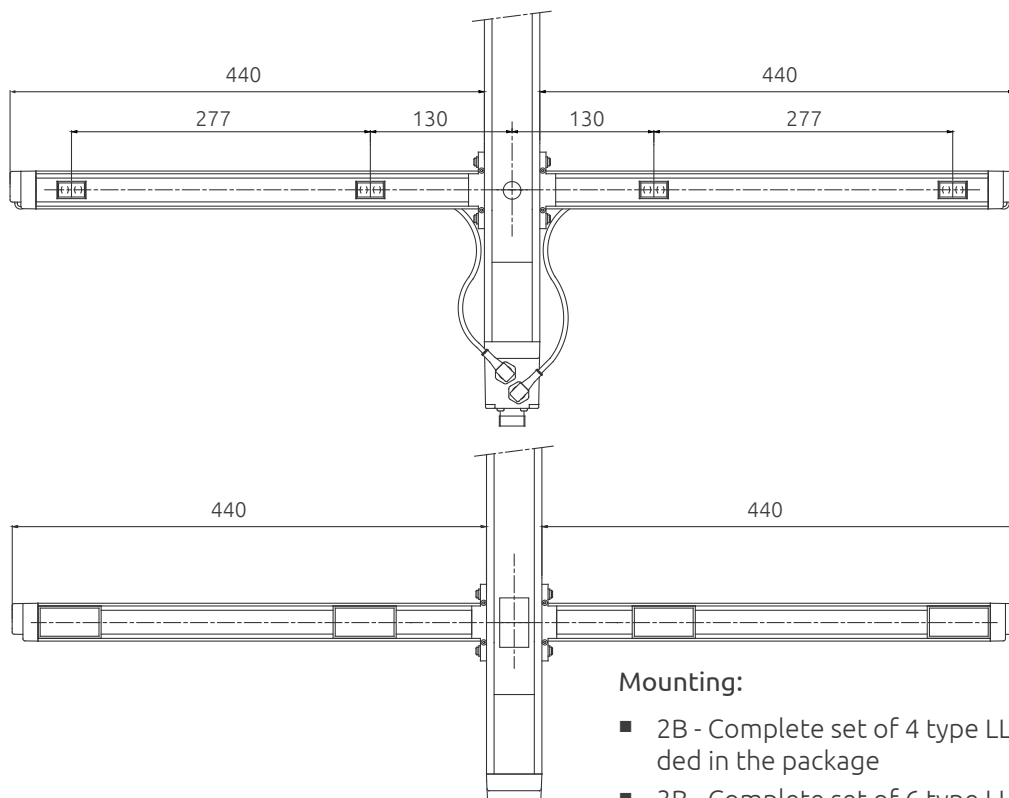

Mounting:

- 2B - Complete set of 4 type LL brackets included in the package
- 3B - Complete set of 6 type LL brackets included in the package

STATUS DISPLAY

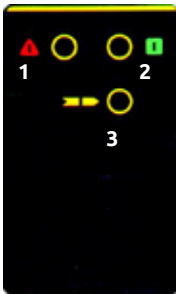

Emitter JANUS ML - MT

1 - Red led	2- Green led	3 - Yellow led	Meaning
			System power-on - Initial TEST for 5 seconds
			Test conditon
			GUARD condition
			FAIL condition. The type of fault is identified by the code number on display. See technical manual



Emitter JANUS MI - J - J LR

1 - Red led	2- Green led	3 - Yellow led	4 - Range	Meaning
				System power-on - Initial TEST for 5 seconds
				Test conditon
				GUARD condition
				FAIL condition.
				High range selected

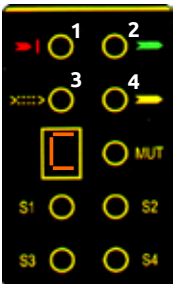

Receiver JANUS MI - ML - MT - MI TRX - ML TRX - MT TRX

1 Break	2 Guard	3 Week	4 Clear/Override	S1 sensor	S2 sensor	S3 sensor	S4 sensor	MUT Muting	Meaning
									System power-on - Initial TEST for 5 seconds. Display shows "8"

In the next 10 seconds, the display and the leds will show the configuration selected.

LED	LED Status	Meaning
S1		Enabling of timeout 30s
S1		Enabling of timeout 90s
S2		With 4 sensors, enabling of sequential Muting
S2		With 4 sensors, enabling of concurrent operation mode
S3		Manual restart functioning mode enabled
S3		Automatic restart functioning mode enabled
S4		External relays feedback control enabled
S4		External relays feedback control disabled
MUT		Muting configuration with 4 sensors
MUT		Muting configuration with 2 sensors
1 - Break		OSSD outputs set to OFF
4 - Clear/override		automatic override with pulse command
4 - Clear/override		manual overrun action with hold to run
Display	C	Configuration

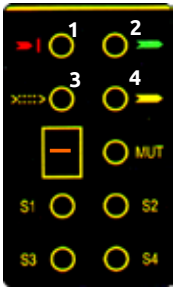

During the normal functioning

LED	LED Status	Meaning
S1		Interruption Sensor 1
		Sensor 1 clear
S2		Interruption Sensor 2
		Sensor 2 clear
S3		Interruption Sensor 3
		Sensor 3 clear
S4		Interruption Sensor 4
		Sensor 4 clear
MUT		Muting active
		Light curtain active - GUARD condition
1 - Break		OSSD outputs set to OFF
2 - Guard		GUARD condition
3 - Week		Weak signal received
		Signal received OK
4 - Clear/override		Light curtain in override, OSSD outputs set ON. "o" letter appears on the display and at the same time the external Muting/Override lamp blinks.
		Override request

Receiver JANUS J - J TRX - J TRX L

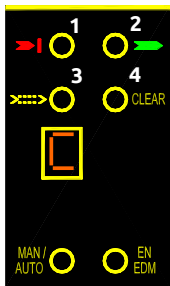

1 Break	2 Guard	3 Week	4 Clear	MAN/AUTO	EN EDM	Meaning
						System power-on - Initial TEST for 5 seconds. Display shows "8"

In the next 10 seconds, the display and the leds will show the configuration selected.

LED	LED Status	Meaning
1 - Break		OSSD outputs set to OFF
MAN/AUTO		Manual restart functioning mode enabled
		Automatic restart functioning mode enabled
EN EDM		External relays feedback control enabled
		External relays feedback control disabled
Display	C	Configuration

During the normal functioning

LED	LED Status	Meaning
1 - Break		OSSD outputs set to OFF
2 - Guard		GUARD condition
3 - Week		Weak signal received
		Signal received OK
4 - Clear		Light curtain clear, OSSD outputs set OFF (the receiver is waiting for a Restart signal)

CODE LEGEND

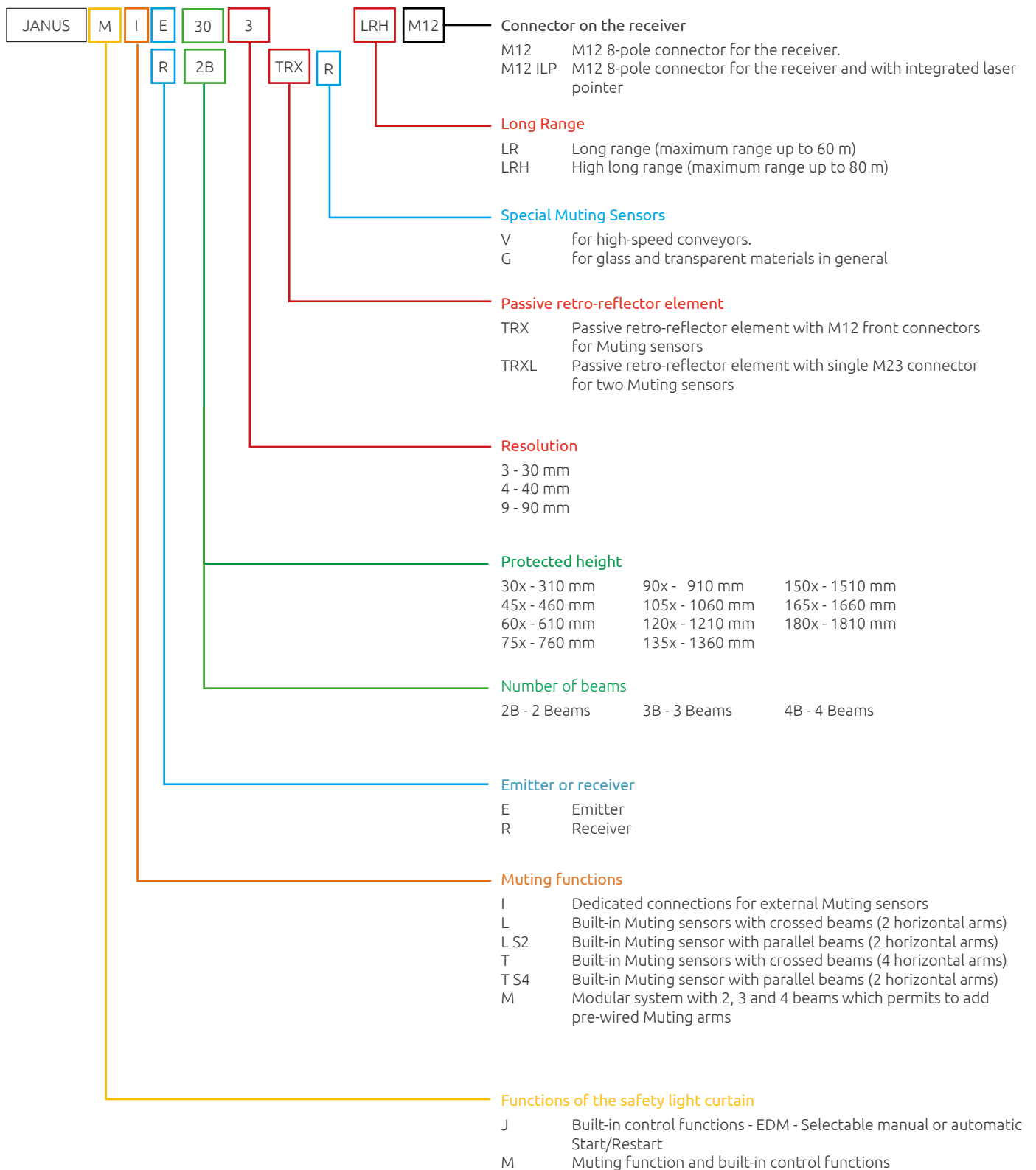

Example:

- JANUS MI E 4B TRX =
- Type 4 safety light curtain Janus family; Emitter
 - Built-in control functions - EDM - Selectable manual or automatic Start/Restart
 - Dedicated connections for external Muting sensors
 - 4 beams - Protected height 910 mm
 - Passive retro-reflector element



AD SR0 - AD SR0A

SAFETY RELAY MODULES FOR DEVICES WITH INTEGRATED FEEDBACK INPUT FOR EDM

TECHNICAL FEATURES

Safety relay outputs	AD SR0 2 NO + 1 NC - 2 A 250 VAC Each NO safety output line is interrupted twice by the two relays
	AD SR0A 2 NO - 2 A 250 VAC
Response time (ms)	≤ 20
Power supply (VDC)	24 ± 20%
Electrical connections	On terminal block
Operating temperature (°C)	0 ... +55
Protection rating	IP20 for housing IP2X for terminal block
Fastening	DIN rail fastening according to EN 50022-35 standard
Dimensions h x w x d (mm)	101 x 35 x 120

PART NUMBERS

AD SR0 and AD SR0A module includes multi-language instruction manual and CE declaration of conformity.

Ordering codes AD SR0: 1330902
AD SR0A: 1330903

Interface relay modules for safety light curtains with feedback input for EDM: Janus.

- Guided-contact safety relays
- Additional NC contact line for the monitoring by light curtain (EDM)

NOTE: AD SR0 and AD SR0A modules can only be connected to safety sensors equipped with feedback input for monitoring external relays (EDM).

Certified by
TÜV Rheinland
Product Safety GmbH

This product uses two guided contact safety relays manufactured by DOLD (type OA or OA 5643 5644) and certified by TUEV Rheinland.





Connection boxes are accessory devices designed for quick, reliable connection of Janus light grids and to ensure that major operating controls needed for operation are available in the guarded area.

- Lighted button for light curtain Start/Restart with green LED for indicating output status and weak signal
- Key selector controlling the override function
- Indicator lamp for Muting function active
- Connector for connection to the light curtain
- Dip switches for configuration of light curtain functions
- 2 Built-in safety relay with guided contacts driven and controlled by the light curtain
- Internal terminal blocks for cable connections
- Selector for connection of external Muting lamp
- Selector for internal or external relay control
- Electrical connection through cable gland
- Versions without Start/Restart and Override commands for connection with Janus J light curtain without Muting.

APPROVALS

- 2004/108/EC "Electromagnetic Compatibility (EMC)"
- 2006/95/EC "Low Voltage Directive (LVD)"
- UL (C+US) mark for USA and Canada



JANUS MJB

CONNECTION BOX FOR JANUS SAFETY LIGHT CURTAINS

TECHNICAL FEATURES

MODELS	MJB 1	MJB 2	MJB 3	MJB 4
Ordering codes	1360930	1360931	1360932	1360933
Override command	yes	no	yes	no
Built-in Muting lamp	yes	no	yes	no
Safety relay output	Relay - 2 contact NO 2A - 250 VAC		Relay - 2 contact NO + 1 NC * 2A - 250 VAC	
Connectors	M23 19-pole for receiver / light curtain connection M12 5-pole for emitter / light curtain connection (not used with TRX light curtains)			
Start/Restart button	yes			
Dimensions h x w x d (mm)	110 x 180 x 110			

* In MJB 3 and MJB 4 boxes each NO safety output line is interrupted twice by the two relays.

All MJB connection boxes can work with any kind of Janus light curtain (with or without Muting).

MJB 1 - MJB 3



MJB 2 - MJB 4



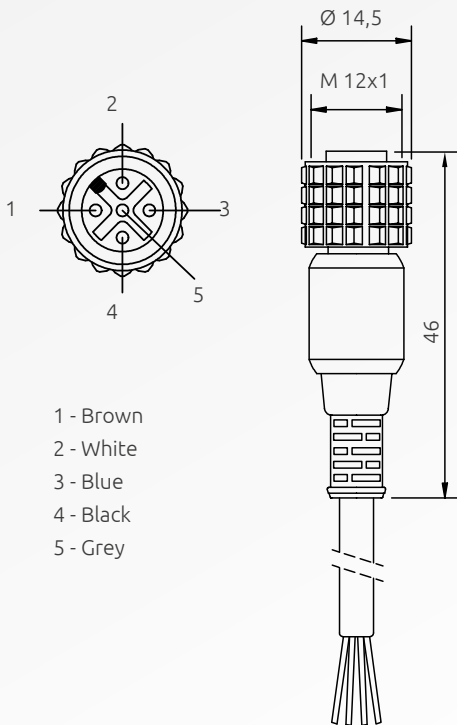
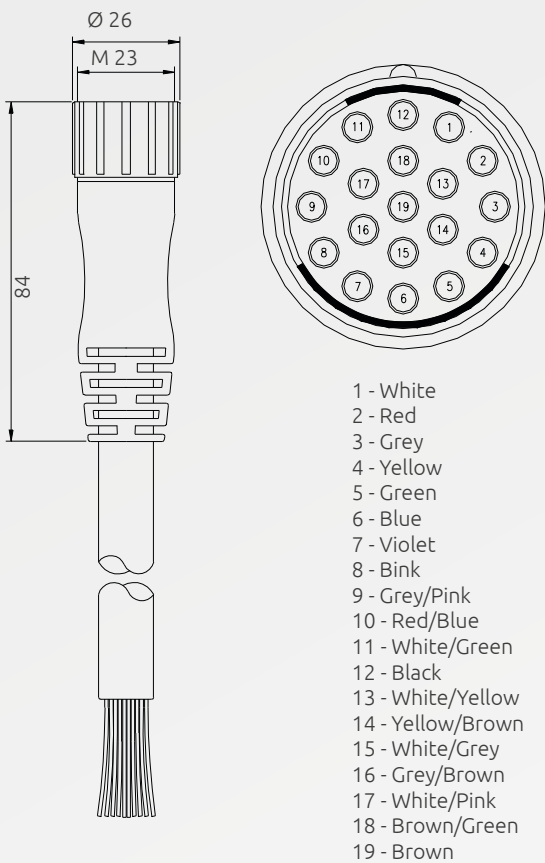

CJx

M23 STRAIGHT CONNECTOR 19-POLE

Model	Codes	Description
CJ3	1360950	Pre-wired cable 3 m
CJ5	1360951	Pre-wired cable 5 m
CJ10	1360952	Pre-wired cable 10 m
CJ15	1360953	Pre-wired cable 15 m
CJ20	1360954	Pre-wired cable 20 m
CJ20L2	1360959	Pre-wired cable 20 m with 2 m long secondary cable for Muting lamp
CJ30	1360964	Pre-wired cable 30 m
CJ30L2	1360979	Pre-wired cable 30 m with 2 m long secondary cable for Muting lamp
CJ35	1360965	Pre-wired cable 35 m
CJ50	1360966	Pre-wired cable 20 m
CJM23	1360955	Cable gland (to be soldered)

CDx

M12 STRAIGHT CONNECTOR 5-POLE

Models	Codes	Description
CD5	1330950	Pre-wired cable 5 m
CD10	1330956	Pre-wired cable 10 m
CD15	1330952	Pre-wired cable 15 m
CD20	1330957	Pre-wired cable 20 m
CD25	1330949	Pre-wired cable 25 m
CD40	1330907	Pre-wired cable 40 m
CD50	1330965	Pre-wired cable 50 m
CD80	1330936	Pre-wired cable 80 m

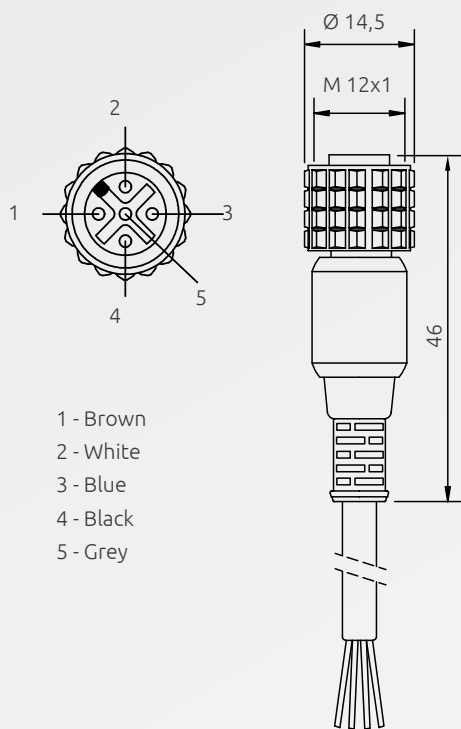

- 1 - Brown
- 2 - White
- 3 - Blue
- 4 - Black
- 5 - Grey

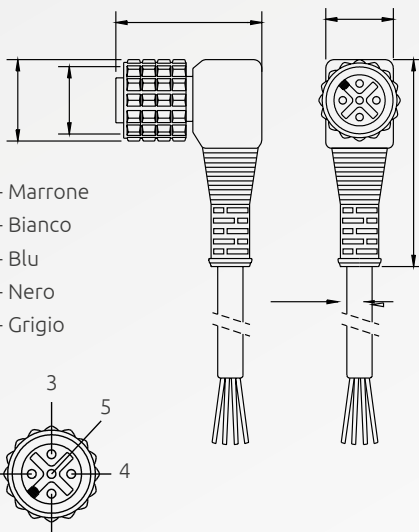

- 1 - Marrone
- 2 - Bianco
- 3 - Blu
- 4 - Nero
- 5 - Grigio

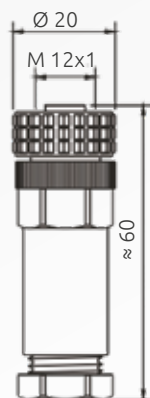

CDx SB

M12 STRAIGHT CONNECTOR 5-POLE, SHIELDED

Models	Codes	Description
CD5 SB	1330850	Pre-wired shielded cable 5 m
CD10 SB	1330856	Pre-wired shielded cable 10 m
CD15 SB	1330852	Pre-wired shielded cable 15 m

CD9x

M12 90° ANGLE CONNECTOR 5-POLE

Models	Codes	Description
CD95	1330951	Pre-wired cable 5 m
CD910	1330958	Pre-wired cable 10 m
CD915	1330953	Pre-wired cable 15 m

CDM9

M12 STRAIGHT CONNECTOR 5-POLE SCREW TERMINAL, PG9 CABLE GLAND

Model	Code
CDM 9	1330954

C8DM9

M12 STRAIGHT CONNECTOR 8-POLE SCREW TERMINAL, PG9 CABLE GLAND

Model	Code
C8DM 9	1330986

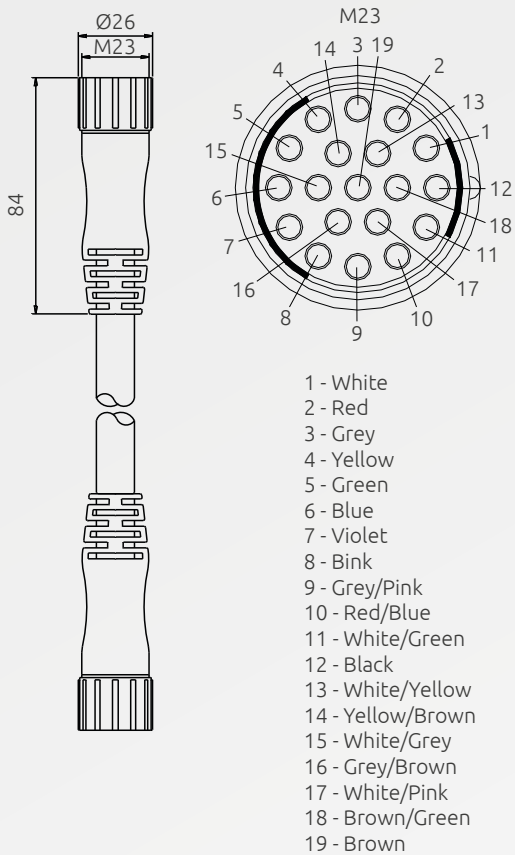

CJBRx

CABLE WITH 2 STRAIGHT CONNECTORS M23 19-POLE

Model	Codes	Description
CJBR3	1360970	Pre-wired cable 3 m
CJBR5	1360971	Pre-wired cable 5 m
CJBR10	1360972	Pre-wired cable 10 m

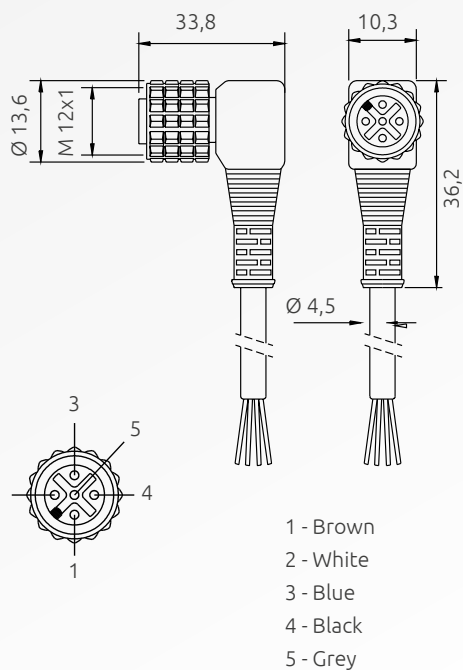

CJ 95

M12 90° ANGLE CONNECTOR 5-POLE

Models	Code	Description
CJ 95	1330983	Pre-wired cable 5 m

CJBEx

CABLE WITH 2 STRAIGHT CONNECTORS M12 5-POLE

Model	Codes	Description
CJBE3	1360960	Pre-wired cable 3 m
CJBE5	1360961	Pre-wired cable 5 m
CJBE10	1360962	Pre-wired cable 10 m
CJBE25	1360963	Pre-wired cable 25 m

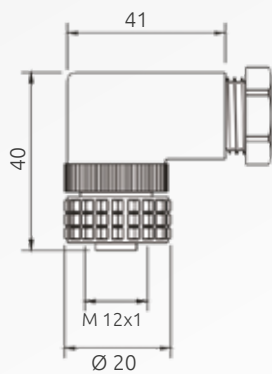
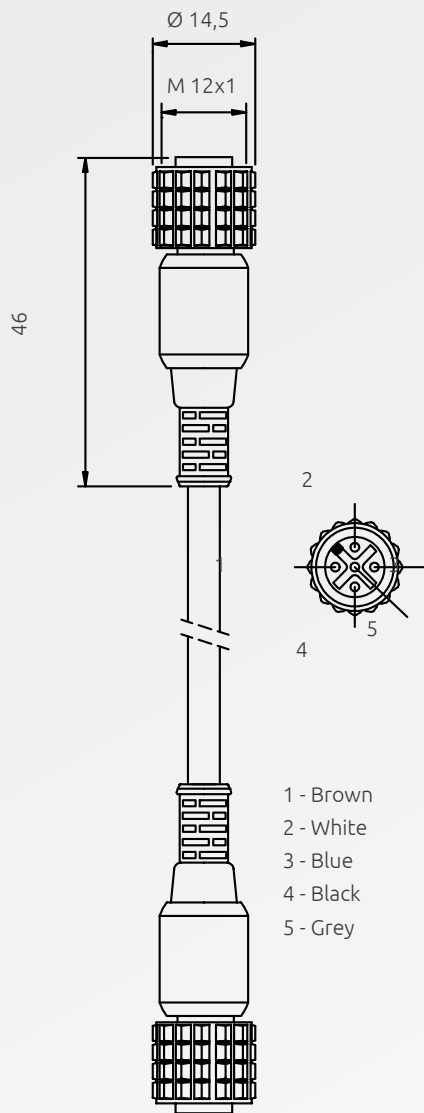

CDM99

M12 90° ANGLE CONNECTOR 5-POLE SCREW TERMINAL, PG9 CABLE GLAND

Models	Codes
CDM99	1330955

C8DM99

M12 90° ANGLE CONNECTOR 8-POLE SCREW TERMINAL, PG9 CABLE GLAND

Models	Codes
C8DM99	1330987

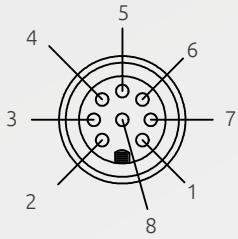

- 1 - White
- 2 - Brown
- 3 - Green
- 4 - Yellow
- 5 - Grey
- 6 - Pink
- 7 - Blue
- 8 - Red

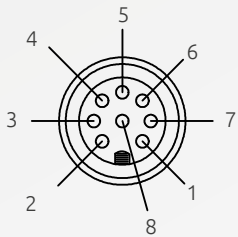
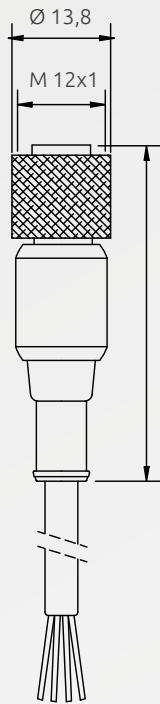

- 1 - White
- 2 - Brown
- 3 - Green
- 4 - Yellow
- 5 - Grey
- 6 - Pink
- 7 - Blue
- 8 - Red

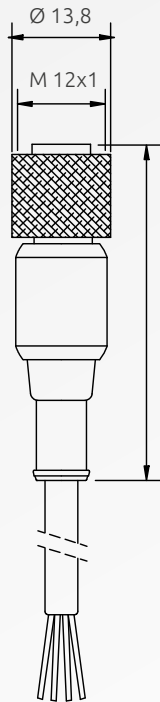

C8Dx

M12 STRAIGHT CONNECTOR 8-POLE

Models	Codes	Description
C8D5	1330980	Pre-wired cable 5 m
C8D10	1330981	Pre-wired cable 10 m
C8D15	1330982	Pre-wired cable 15 m
C8D25	1330967	Pre-wired cable 25 m
C8D40	1330966	Pre-wired cable 40 m
C8D50	1330909	Pre-wired cable 50 m
C8D70	1330937	Pre-wired cable 70 m

C8Dx SB

M12 STRAIGHT CONNECTOR 8-POLE, SHIELDED

Model	Codes	Description
C8D5 SB	1330880	Pre-wired shielded cable 5 m
C8D10 SB	1330881	Pre-wired shielded cable 10 m
C8D15 SB	1330882	Pre-wired shielded cable 15 m

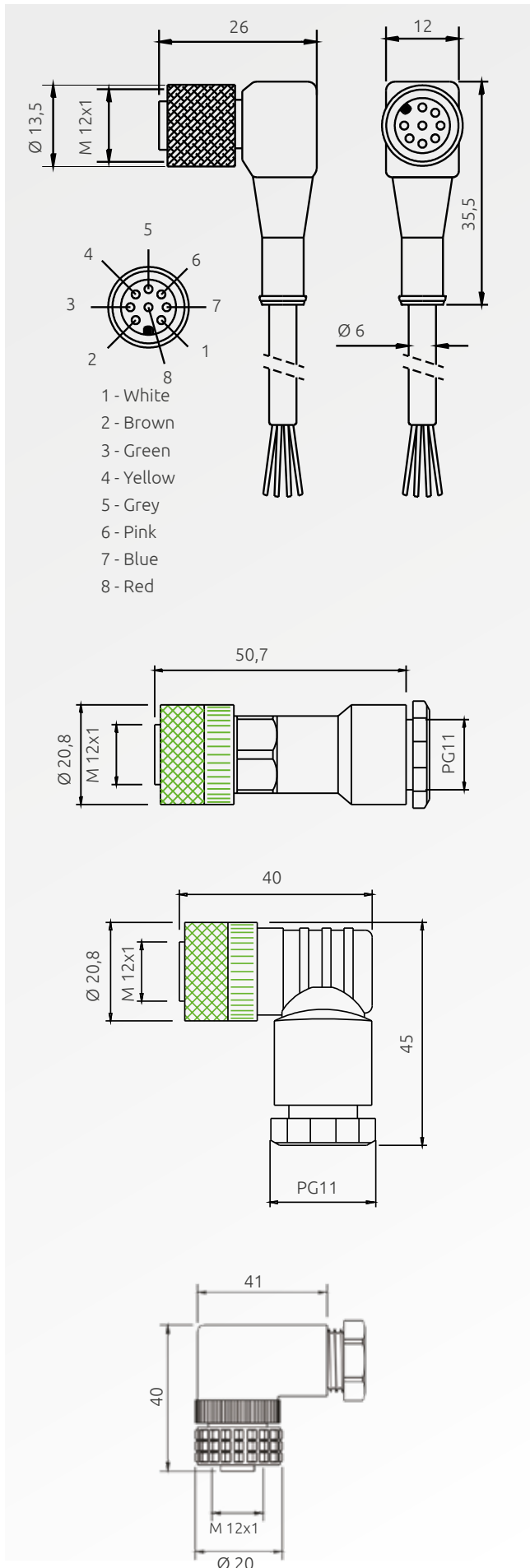

C8D9x

M12 90° ANGLE CONNECTOR 8-POLE

Models	Codes	Description
C8D95	1330983	Pre-wired cable 5 m
C8D910	1330984	Pre-wired cable 10 m
C8D915	1330985	Pre-wired cable 15 m

C8DM11

M12 STRAIGHT CONNECTOR 8-POLE SCREW TERMINAL, PG11 CABLE GLAND

Model	Code
C8DM11	1330978

C8DM 911

M12 90° ANGLE CONNECTOR 8-POLE SCREW TERMINAL, PG11 CABLE GLAND

Model	Code
C8DM911	1330979

CJM9

M12 90° ANGLE CONNECTOR 5-POLE SCREW TERMINAL, PG9 CABLE GLAND

Model	Code
CJM99	1360982

JANUS SL TRX e ST TRX

ACCESSORY MUTING SENSOR ELEMENTS FOR JANUS MM

TECHNICAL FEATURES

MODELS	SL TRX	ST TRX
Ordering codes	1360695	1360696
Optoelectronics sensors	2 parallel beams	2 parallel beams
Operating range (m)	0 ... 3,5	0 ... 3,5

Note for ordering

- To form a L logic system you need:
Light curtain JANUS MM TRX + SL TRX
- To form a T logic system you need:
Light curtain JANUS MM TRX + SL TRX + ST TRX

Janus SL TRX Muting arm, with active and passive retro-reflector elements, in combination with Janus MM TRX models form a one-way access control system with L logic (only exit).

Together with Janus SL TRX and ST TRX Muting arms, Janus MM TRX models become a two-way access control system with T logic (two-way).

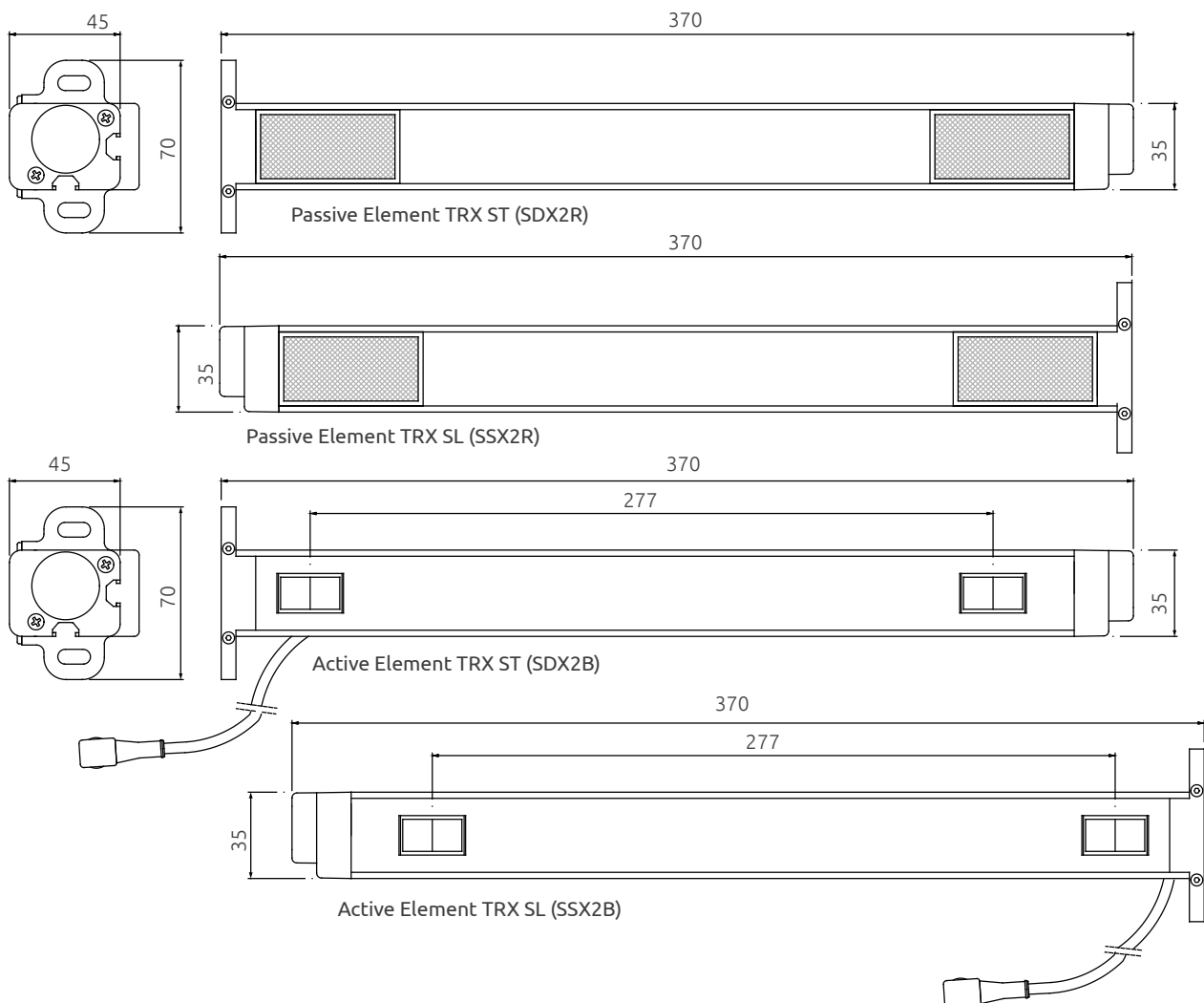

JANUS SL

ACCESSORY MUTING SENSOR ELEMENTS FOR JANUS MI

TECHNICAL FEATURES

MODELS	SL	S2L
Ordering codes	1360060	1360061
Optoelectronics sensors	2 crossed beams	2 parallel beams
Operating range (m)	1 ... 2,5	0 ... 2

The SL series accessory Muting sensor elements (arms) can be combined with the Janus MI light curtain model, making it possible to create an "L" barrier with built-in sensors with 30, 40, 90 mm resolution and protected height from 310 to 1810 mm.

The SL and S2L models have 2 built-in sensors, pre-wired and pre-aligned, with crossed or parallel beams.

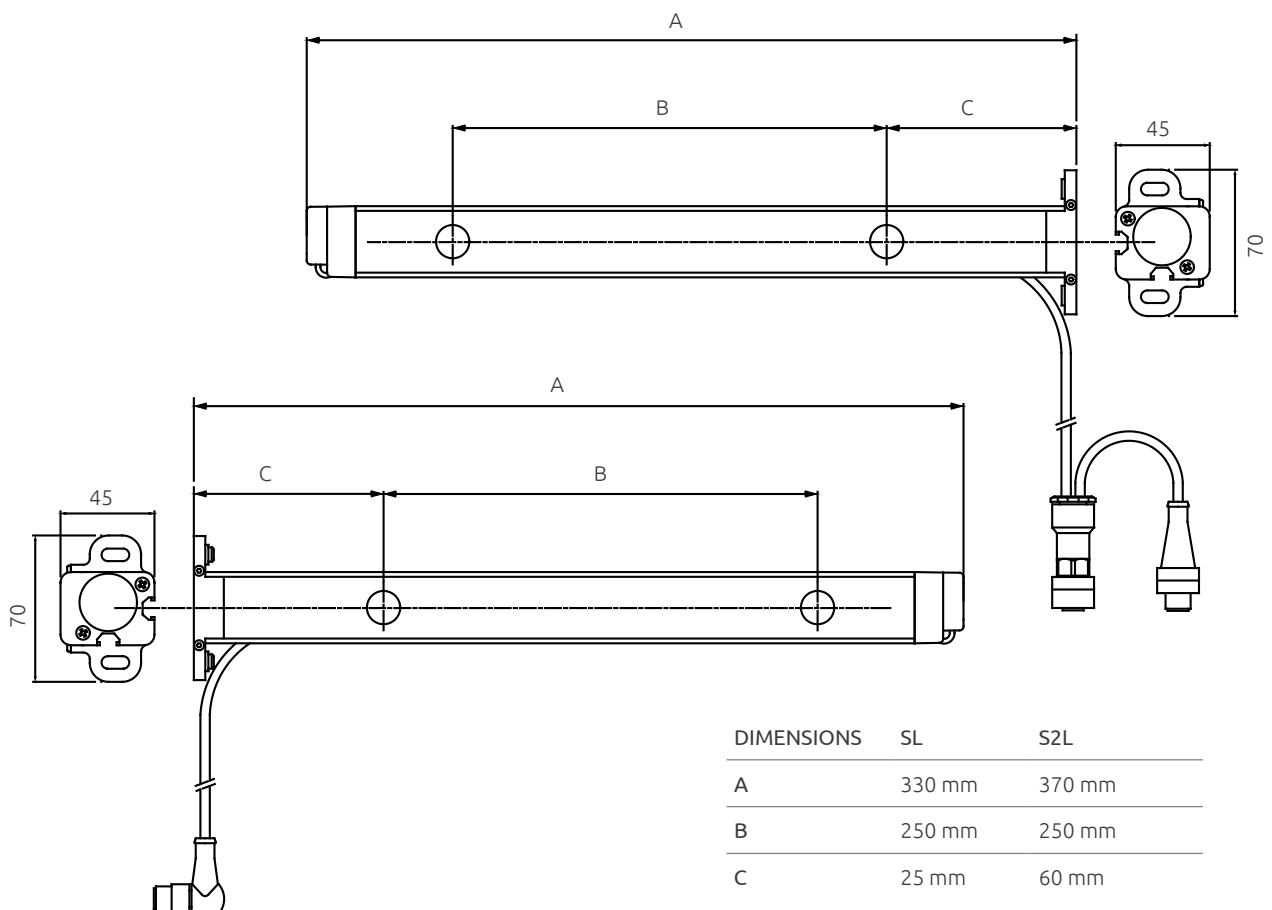

FMC B / FMC BR

FLOOR SUPPORT COLUMNS FOR LIGHT CURTAINS

PART NUMBERS

Columns

Standard Models	FMC B 2	FMC B 3	FMC B 4	FMC B 1700	FMC B 2000
Ordering codes	1200610	1200611	1200612	1200618	1200616
Models with PG11 rear union for cable sheath	FMC B 2 R	FMC B 3 R	FMC B 4 R	FMC B 1700 R	FMC B 2000 R
Ordering codes	1200613	1200614	1200615	1200617	1200619
A - Height (mm)	1000	1200	1330	1670	1970
B - Overall height with FMC CB base (mm)	1055	1255	1385	1725	2025
B - Overall height with FMC CBL base (mm)	1037	1237	1367	1707	2007
For light curtains with:	2 beams	3 beams	4 beams	controlled height up to 1360 mm	controlled height up to 1660 mm

Bases for columns

Models	FMC CB	FMC CBL
Ordering codes	1200500	1200501
Description	Base for column	Base for column with reduced height
Height (mm)	55	37

Note for ordering

The column ordering codes does not include the base which must be ordered separately (FMC CB and FMC CBL models)

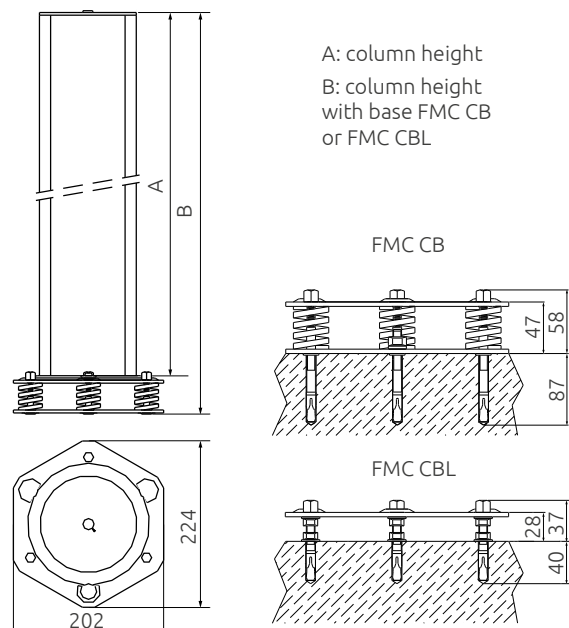

Support columns for Reer safety light curtains, designed to provide secure fastening to the floor, fast installation, and a simple and precise adjustment of the optical alignment of the system.



PG11 Cable gland
FMC BR Models

Steel base with springs for a perfect adjustment of the column vertical axis. FMC BR models for light curtains complete with PG11 rear union for light curtain cable sheath.

Columns made by aluminium extrusion poles, with adjustable angular orientation. Easy assembling and disassembling of the light curtain with easy adjustment of the first beam's height.

Steel foundation inserts included with the product.

Built-in spirit level for a correct positioning of the vertical axis.



FMC B12 / B18 SUPPORT COLUMNS

PARTS NUMBERS

Model	FMC B12	FMC B18
Ordering codes	1200502	1200505
Dimensions (mm)	60 x 30	80 x 80
Height (mm)	1200	1800
Overall height with FMC CB base (mm)	1255	1255
Overall height with FMC CBL base (mm)	1237	1237

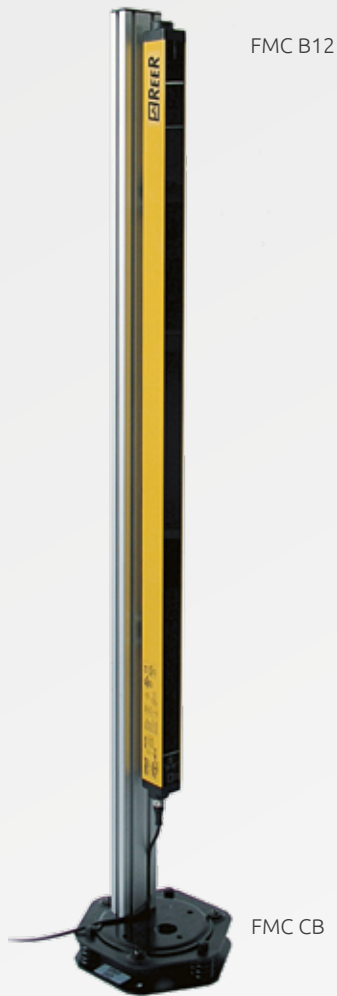

Simplified version for 2, 3, 4 beams light grids. It permits the use with light grids with integrated Muting sensors.

Note for ordering

The column ordering codes does not include the base which must be ordered separately (FMC CB and FMC CBL models)

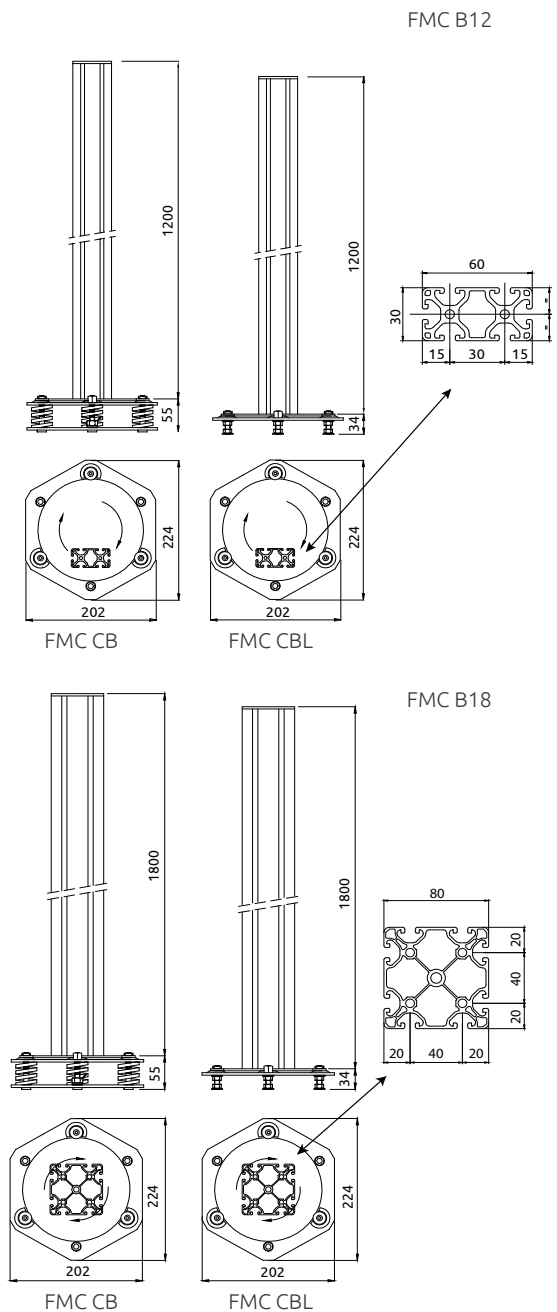

FMC S / FMC SB

COLUMNS WITH DEFLECTING MIRROR

PART NUMBERS

Models	FMC S2	FMC S3	FMC S4	FMC S 1700	FMC S 2000
Ordering codes	1200620	1200621	1200622	1200625	1200623
Description	single mirror for 2 beams and controlled height up to 700 mm light curtains	single mirror for 3 beams and controlled height up to 900 mm light curtains	single mirror for 4 beams and controlled height up to 900 mm light curtains	single mirror for controlled height up to 1360 mm	single mirror for controlled height up to 1660 mm
A - Height (mm)	1000	1200	1330	1670	1970
B - Overall height with FMC CB base (mm)	1055	1255	1385	1725	2025
B - Overall height with FMC CBL base (mm)	1037	1237	1367	1707	2007

Models	FMC SB2	FMC SB3	FMC SB4
Ordering codes	1200645	1200646	1200647
Description	2 mirrors for 2 beams light curtains	3 mirrors for 3 beams light curtains	4 mirrors for 4 beams light curtains
A - Height (mm)	1000	1200	1330
B - Overall height with FMC CB base (mm)	1055	1255	1385
B - Overall height with FMC CBL base (mm)	1037	1237	1367

Note for ordering

The column ordering codes does not include the base which must be ordered separately (FMC CB and FMC CBL models)



Support columns for deflecting mirrors, designed to provide secure fastening to the floor, fast installation, and a simple and precise adjustment of the optical alignment of the system.

FMC S models with pre-assembled deflecting mirrors, allow perimeter protections of up to 4 sides.

FMC SB models with pre-installed independent adjustable deflecting mirrors for safety light grids with 2, 3 and 4 beams. For applications with multiple sides and/or with a large protected perimeter is recommended the use of this models.

Optical power reduction factor: 15% for each mirror.

Special models equipped with mirror with protective anti-fragmentation film available on request.

NOTE: for more information on how to chose mirrors, please refers to Reer website, section "Light Curtains - Applications".

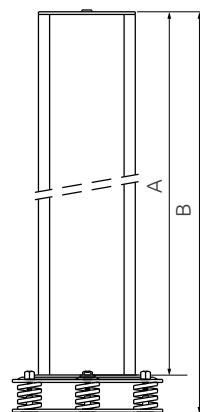

A: column height
B: column height with base FMC CB or FMC CBL

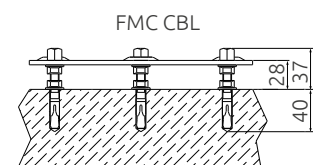
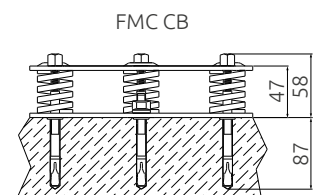
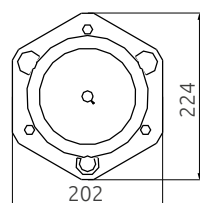

SP

DEFLECTING MIRRORS

TECHNICAL FEATURES

Material	Extruded aluminium
Mirror pre-fitted with heights (mm)	250 ... 1900
Angular orientation	Adjustable using supplied brackets
Optical power reduction factor	15% (for each mirror)
Protective anti-fragmentation film	Available on request

PART NUMBERS

Mirror Model	Ordering codes	Height H in picture (mm)	For light curtains with protected height (mm)	For light grids with:
SP 100 S	1201805	250	160	
SP 200 S	1201800	370	250	
SP 300 S	1201806	400	310	
SP 400 S	1201801	540	460	
SP 600 S	1201811	715	610	2 beams
SP 700 S	1201802	885	760	
SP 900 S	1201812	1065	910	3 beams
SP 1100 S	1201803	1230	1060	4 beams
SP 1200 S	1201810	1400	1210	
SP 1300 S	1201807	1450	1360	
SP 1500 S	1201808	1600	1510	
SP 1600 S	1201813	1750	1660	
SP 1800 S	1201809	1900	1810	

The SP deflecting mirrors make it possible to create perimeter protection of areas with access points on multiple sides, with a considerable reduction of costs.

This solution eliminates the need to use more than one safety light curtain. Can be used to realise perimeter protection up to 4 sides.

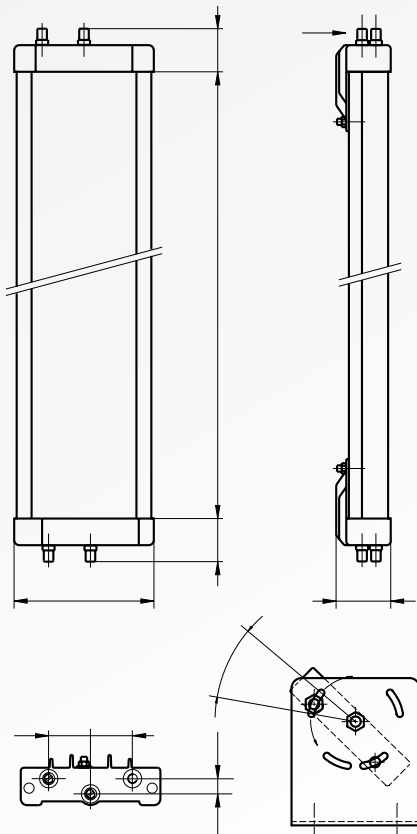

The following rules should be taken into consideration when using deflecting mirrors:

- Total working distance (range) given by the sum of the lengths of all sides giving access to the protected area
- Each mirror used will decrease the maximum working range between the Emitter and the Receiver by 15%
- In order to ensure compliance mirrors must be placed at the minimum safety distance on each side from the danger zone
- The use of the LAD laser alignment device is recommended for a quick and reliable alignment of the system especially when using longer range light curtains or grids

NOTE: for more information on how to choose mirrors, please refer to Reer website, section "Light Curtains - Applications".



The SAV vibration dampers have been designed to avoid mechanical damage to the light curtains installed in those applications which have a high level of vibrations.

The unprotected light curtains might resent the vibrations produced by e.g. presses, weaving machines, etc.



The SFB 4J swivel brackets allow the rotation of the light curtain around its longitudinal axis, as well as the adjustment of its vertical and horizontal position.

The use of the SFB 4J swivel brackets is recommended to align those light curtains which are employed in applications having a long range or using deflecting mirrors.

SAV 1, SAV 2 VIBRATION DAMPERS

PARTS NUMBERS

Model	Ordering codes	Description	For light curtains with protected height mm / beams
SAV 1	1200084	set 4 vibrations dampers	310... 1060 / 2,3,4 beams
SAV 2	11200085	set 6 vibrations dampers	1210 ... 1810

2 set must be ordered for each light curtain.

SFB 4J SWIVEL BRACKETS

PARTS NUMBERS

Model	Ordering codes	Description
SFB 4J	1360068	set of 4 swivel brackets

One set must be ordered for each pair of light curtain (emitter + receiver)



The LAD 3 laser alignment device makes it possible to obtain a fast and reliable optical alignment of the ReeR safety light curtains; they are also compatible with the use of the FMC floor mounting columns.

The LAD 3 devices emit a laser beam with visible red light with useful range up to 100 m.

Their use is recommended for aligning light curtains that operate over long distances or multiple sides with the use of deflecting mirrors.

PART NUMBERS

Each LAD model includes multi-language instruction manual.

Ordering code LAD 3: 1220302



The test rod is an opaque cylinder used after the installation of a safety light curtain to check that no beams are bypassed due to the presence of reflecting surfaces.

The test is carried out by slowly moving the test rod (\emptyset = Resolution) in the centre and then along each side of the protected area. During this procedure the Green led on the Receiver must always remain in the off state.

LAD 3

LASER ALIGNMENT DEVICE

TECHNICAL FEATURES

Light source	Laser diode – wavelength 650 nm
Class light source	II – EN 60825-1
Range m	100
Beam divergence (mrd)	< 0,5
Max. power (mW)	1
Power supply (VDC)	3 (2 AAA batteries)
Fastening	Quick fastening to the light curtains
Dimensions h x w x d (mm)	70 x 78 x 70

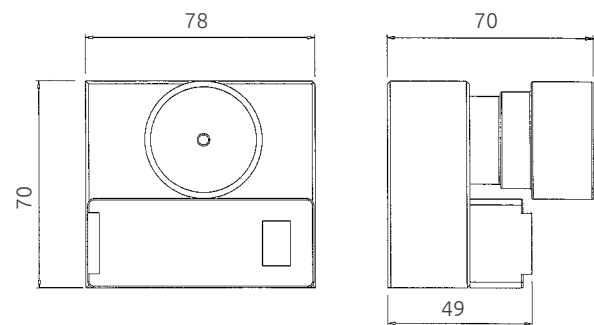

TR

TEST ROD

PART NUMBERS

Model	Ordering codes	Diameter
TR 14	1330960	\emptyset 14 mm
TR 20	1330961	\emptyset 20 mm
TR 30	1330962	\emptyset 30 mm
TR 40	1330963	\emptyset 40 mm
TR 50	1330964	\emptyset 50 mm

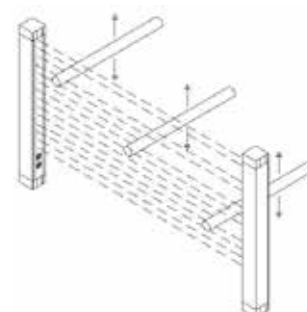



REEER *Customer Service*

We put our Customers always first

ReeR after sales service is committed to support all customers that need technical guidance regarding functionality, handling and installation of our products.

Customer Service Hotline

+39 011 24 82 215

Monday to Friday 8.30 - 12.30 and 13.30-18.00 (CET)

or contact

aftersales@reer.it

For product returns please visit www.reersafety.com for further information.



Your future's safe!

More than 60 years of quality and innovation

Founded in Turin (Italy) in 1959, ReeR distinguished itself for its strong commitment to innovation and technology.

A steady growth throughout the years allowed ReeR to become a point of reference in the safety automation industry at a worldwide level.

The Safety Division is in fact today a world leader in the development and manufacturing of safety optoelectronic sensors and controllers.

ReeR is ISO 9001, ISO 14001 and ISO 45001 certified.



ReeR SpA
Via Carcano, 32
10153 Torino, Italy
T +39 011 248 2215
F +39 011 859 867

www.reersafety.com | info@reer.it



Issue 2 - Rev. 1.3
February 2021
8946229
JANUS - English

Printed in Italy

